

Thermal Mass Flowmeter Sensyflow FMT200-D

for compressed air and biogas
applications



Thermal Mass Flowmeter Sensyflow FMT200-D

Operating Instruction

42/14-37-EN

06.2012

Rev. 06

Translation of the original instruction

Manufacturer:

**ABB Automation Products GmbH
Process Automation**

Dransfelder Straße 2
D-37079 Göttingen
Germany
Tel.: +49 551 905-534
Fax: +49 551 905-555

Customer service center

Phone: +49 180 5 222 580
Fax: +49 621 381 931-29031
automation.service@de.abb.com

© Copyright 2012 by ABB Automation Products GmbH
Subject to changes without notice

This document is protected by copyright. It assists the user in safe and efficient operation of the device. The contents of this document, whether whole or in part, may not be copied or reproduced without prior approval by the copyright holder.

1	Safety	4
1.1	General information and notes for the reader	4
1.2	Intended use.....	4
1.2.1	General information.....	5
1.2.2	Installing / Disassembling pipe components.....	6
1.2.3	Installing / Disassembling the flowmeter sensor	6
1.3	Target groups and qualifications	6
1.4	Warranty provisions.....	6
1.5	Plates and symbols	7
1.5.1	Safety- / warning symbols, note symbols.....	7
1.6	Name plates	8
1.7	Safety instructions for electrical installation	8
1.7.1	Safety instructions for operation	8
1.8	Returning devices.....	9
1.9	Integrated management system.....	9
1.10	Disposal.....	10
1.10.1	Information on WEEE Directive 2002/96/EC (Waste Electrical and Electronic Equipment).....	10
1.10.2	RoHS Directive 2002/95/EC	10
2	Design and function	11
2.1	Pipe components.....	12
2.2	Flowmeter sensor	12
3	Mounting	13
3.1	Recommended steadying lengths according to DIN EN ISO 5167-1	13
3.2	Verifying the conditions	14
3.3	Selecting the installation site	14
3.4	Installing the flowmeter sensor and pipe components	15
3.5	Weld-on adapter for Sensyflow FMT200-D.....	16
4	Electrical connections	18
5	Commissioning	19
5.1	Checking the installation	19
5.2	Connecting the power supply	19
5.3	Switching on	19
6	Parameterization	20
7	Error messages	20
8	Specifications	21
9	Dimensions	22
9.1	Pipe component	22
9.2	Weld-on adapter for Sensyflow FMT200-D.....	23
10	Appendix	24
10.1	Decommissioning and packaging	24
10.2	Approvals and certifications	24

1 Safety

1.1 General information and notes for the reader

You must read these instructions carefully prior to installing and commissioning the device. These instructions are an important part of the product and must be kept for future reference. These instructions are intended as an overview and do not contain detailed information on all designs for this product or every possible aspect of installation, operation and maintenance. For additional information or if specific problems occur that are not discussed in these instructions, contact the manufacturer.

The content of these instructions is neither part of any previous or existing agreement, promise or legal relationship nor is it intended to change the same.

This product is built based on state-of-the-art technology and is operationally safe. It has been tested and left the factory in perfect working order from a safety perspective. The information in the manual must be observed and followed in order to maintain this state throughout the period of operation.

Modifications and repairs to the product may only be performed if expressly permitted by these instructions.

Only by observing all of the safety instructions and all safety/warning symbols in these instructions can optimum protection of both personnel and the environment, as well as safe and fault-free operation of the device, be ensured.

Information and symbols directly on the product must be observed. They may not be removed and must be fully legible at all times.

1.2 Intended use

Mass flow measurement of gases and gas mixtures in closed pipelines.

Can be used:

- As a plug-in sensor in the pipe component in pipelines with nominal diameters 1 ... 3",
- With weld-in adapter directly in pipelines with nominal diameters DN 100 ... DN 250 (4 ... 10").
- The permissible process temperature range is -25 ... 150 °C (-13 ... 302 °F).



WARNING

These devices are not permitted for use in zone 0 or zone 1 potentially explosive atmospheres.

The device is designed for use exclusively within the values stated on the name plate and in the technical specifications (see the section titled "Specifications").

1.2.1 General information

- The device (including the pipe components) has been designed, produced and approved in accordance with Pressure Equipment Directive 97/23/EC. The pipe components take the form of a
 - External thread design with integrated measuring section,
 - Flange design with integrated measuring section
 - Weld-on adapter
- The thermal mass flowmeters are a component of the pipeline. A rating of the entire system according to PED is to be carried out by the approved regulatory agency on the customer side.
- The FMT200-D measuring systems are intended exclusively for measuring the flow of gaseous media.
- The device may only be used in accordance with the application specified on the order confirmation; other operating conditions may prevent the device from functioning correctly, cause damage to it or even damage it beyond repair.
- Care must be taken to ensure that the measuring media used do not impair the chemical and physical properties of the components that come into contact with the fluids concerned.
- The threshold value for alternating load cycles corresponds to AD-2000 instruction sheet S1, Section 1.4 and is not calculated or checked by the manufacturer.
- The device should be included in any regular maintenance activities that are carried out on the entire system.
- The materials used must be checked by the user to ensure their suitability for the application concerned.
- The maximum operating conditions relating to pressure and temperature, as stated on the name plate / in the operating instructions, must not be exceeded.
- When installing and disassembling pipe components or flowmeter sensors, ensure that the pipeline has been depressurized.
- Before carrying out installation work on pipelines used to carry aggressive or toxic measuring media, media that may be classed as irritant, or other kinds of hazardous media, the fluids concerned must be adequately flushed out. Compliance with the relevant accident prevention regulations must also be ensured.
- If damaged, components must no longer be used. They must be taken out of circulation and sent to the manufacturer for repair.
- If disassembled components have come into contact with aggressive or toxic measuring media, media that may be classed as irritant, or other kinds of hazardous media, before being sent off they must be cleaned and then packed and labeled accordingly.
- If leaks occur at the measuring point, it must immediately be taken out of service.
- Defective gaskets or O-rings must be removed from use and must be replaced as a matter of urgency.
- The subsequent mechanical labeling or machining of pipe components and flowmeter sensors can result in damage and is prohibited.
 - Exception: Cutting to length and welding onto the pipeline in the case of weld-on adapters.

1.2.2 Installing / Disassembling pipe components

- During installation, it is important to ensure that the flow direction corresponds to the attached label.
- When welding the weld-on adapter, remember to observe the relevant welding instructions. The amount of heat introduced must be kept to an absolute minimum to prevent warping of the mounting flange's sealing surface.
- In the case of flanged connections, flat gaskets must be installed. These must be in perfect condition and resistant to the measuring media.
- Before installing pipe components or flowmeter sensors, check all components and gaskets for damage.
- Pipe components must not be installed under tension, otherwise the pipeline may be subjected to impermissible forces.
- When assembling the flanged connections, use screws that offer the required strength and dimensions.
- The screws must be tightened evenly and to the required torque.
- Once the pipe components have been installed, the insertion connection must be sealed by means of a blind flange plus gasket or by closing a shut-off device (if present).

1.2.3 Installing / Disassembling the flowmeter sensor

- Installation in the pipe component or weld-on adapter is only possible if the flowmeter sensor data matches the measuring point specifications.
- It is very important to use the O-ring supplied (not a flat gasket). This is resistant to measuring media and should be inserted in the groove provided in the pipe component flange.
- Take care not to damage the measuring elements when inserting the flowmeter sensor into the pipe component, as this is not permitted.
- The flowmeter sensor should be firmly bolted together with the flange of the insertion connection. The screws must be tightened evenly to the required torque.

1.3 Target groups and qualifications

Installation, commissioning, and maintenance of the product may only be performed by trained specialist personnel who have been authorized by the plant operator to do so. The specialist personnel must have read and understood the manual and comply with its instructions.

Prior to using corrosive and abrasive materials for measurement purposes, the operator must check the level of resistance of all parts coming into contact with the materials to be measured. ABB Automation Products GmbH will gladly support you in selecting the materials, but cannot accept any liability in doing so.

The operators must strictly observe the applicable national regulations with regards to installation, function tests, repairs, and maintenance of electrical products.

1.4 Warranty provisions

Using the device in a manner that does not fall within the scope of its intended use, disregarding this instruction, using underqualified personnel, or making unauthorized alterations releases the manufacturer from liability for any resulting damage. This renders the manufacturer's warranty null and void.

1.5 Plates and symbols

1.5.1 Safety- / warning symbols, note symbols



DANGER – <Serious damage to health / risk to life>

This symbol in conjunction with the signal word "Danger" indicates an imminent danger. Failure to observe this safety information will result in death or severe injury.



DANGER – <Serious damage to health / risk to life>

This symbol in conjunction with the signal word "Danger" indicates an imminent electrical hazard. Failure to observe this safety information will result in death or severe injury.



WARNING – <Bodily injury>

This symbol in conjunction with the signal word "Warning" indicates a possibly dangerous situation. Failure to observe this safety information may result in death or severe injury.



WARNING – <Bodily injury>

This symbol in conjunction with the signal word "Warning" indicates a potential electrical hazard. Failure to observe this safety information may result in death or severe injury.



CAUTION – <Minor injury>

This symbol in conjunction with the signal word "Caution" indicates a possibly dangerous situation. Failure to observe this safety information may result in minor or moderate injury. This may also be used for property damage warnings.



NOTICE – <Property damage>!

The symbol indicates a potentially damaging situation.

Failure to observe this safety information may result in damage to or destruction of the product and/or other system components.



IMPORTANT (NOTE)

This symbol indicates operator tips, particularly useful information, or important information about the product or its further uses. It does not indicate a dangerous or damaging situation.

1.6 Name plates

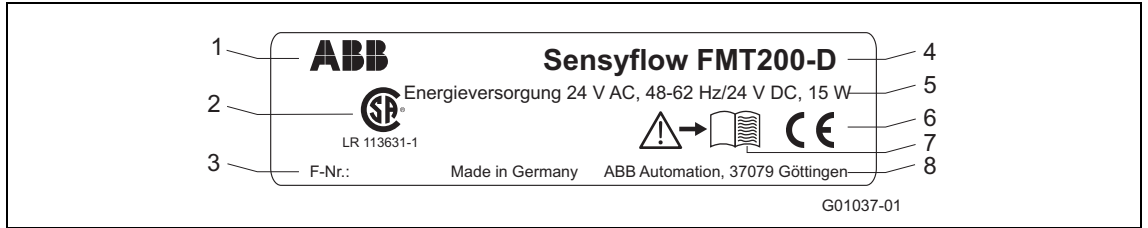

Fig. 1

- | | |
|-------------------------------------|---------------------------------------|
| 1 Device manufacturer | 5 Permissible supply power, frequency |
| 2 Labeling, e. g., for CSA approval | 6 CE mark (EC conformity) |
| 3 Serial number | 7 Refer to product documentation |
| 4 Type designation | 8 Country of manufacture |

1.7 Safety instructions for electrical installation

The electrical connection may only be made by authorized specialist personnel according to the electrical plans.

The electrical connection information in the manual must be observed; otherwise, the electrical protection type may be adversely affected.

Ground the measurement system according to requirements.

1.7.1 Safety instructions for operation



WARNING

Touching the surface can lead to burns if the measuring media are hot. This can result in severe injuries or death. Do not touch.



WARNING

If the measuring medium is allowed to escape in an uncontrolled manner, this can result in severe injuries or death. Check pipelines and gaskets on a regular basis.

1.8 Returning devices

Use the original packaging or a secure transport container of an appropriate type if you need to return the device for repair or recalibration purposes. Fill out the return form (see the Appendix) and include this with the device.

The EU Directive governing hazardous materials dictates that the owners of any hazardous waste are also responsible for disposing of it.

All devices delivered to the manufacturer must be free from any hazardous materials (acids, alkalis, solvents, etc.).

Pipe components and flowmeter sensors contain hollow spaces. If they have been used in conjunction with hazardous materials, they must therefore be rinsed out in order to neutralize any such substances.

The owner will be charged for any costs incurred as a result of the device not having been adequately cleaned or of any failure to dispose of hazardous materials. The manufacturer reserves the right to return a contaminated device.

Please contact Customer Center Service acc. to page 2 for nearest service location.

1.9 Integrated management system

ABB Automation Products GmbH operates an integrated management system, consisting of:

- Quality management system to ISO 9001:2008
- Environmental management system to ISO 14001:2004
- Occupational health and safety management system to BS OHSAS 18001:2007 and
- Data and information protection management system

Environmental awareness is an important part of our company policy.

Our products and solutions are intended to have a minimal impact on the environment and on people during manufacturing, storage, transport, use, and disposal.

This includes the environmentally-friendly use of natural resources. We conduct an open dialog with the public through our publications.

1.10 Disposal

This product is manufactured from materials that can be reused by specialist recycling companies.

1.10.1 Information on WEEE Directive 2002/96/EC (Waste Electrical and Electronic Equipment)

This product is not subject to WEEE Directive 2002/96/EC or relevant national laws (e.g., ElektroG in Germany).

The product must be disposed of at a specialist recycling facility. Do not use municipal garbage collection points. According to the WEEE Directive 2002/96/EC, only products used in private applications may be disposed of at municipal garbage facilities. Proper disposal prevents negative effects on people and the environment, and supports the reuse of valuable raw materials.

If it is not possible to dispose of old equipment properly, ABB Service can accept and dispose of returns for a fee.

1.10.2 RoHS Directive 2002/95/EC

With the Electrical and Electronic Equipment Act (ElektroG) in Germany, the European Directives 2002/96/EC (WEEE) and 2002/95/EC (RoHS) are translated into national law. ElektroG defines the products that are subject to regulated collection and disposal or reuse in the event of disposal or at the end of their service life. ElektroG also prohibits the marketing of electrical and electronic equipment that contains certain amounts of lead, cadmium, mercury, hexavalent chromium, polybrominated biphenyls (PBB), and polybrominated diphenyl ethers (PBDE) (also known as hazardous substances with restricted uses).

The products provided by ABB Automation Products GmbH do not fall within the current scope of the directive on waste from electrical and electronic equipment according to ElektroG. If the necessary components are available on the market at the right time, in the future these substances will no longer be used in new product development.

2 Design and function

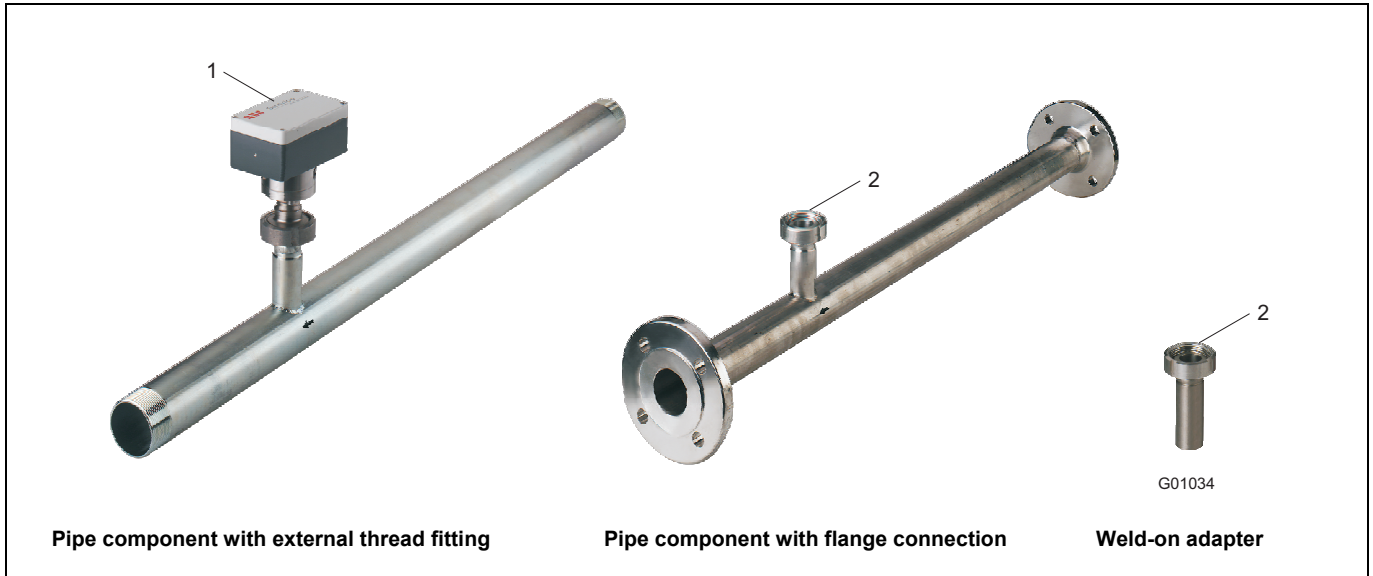

Fig. 2

- 1 Flowmeter sensor Sensyflow FMT200-D
- 2 Lock nut

The mass flowmeter works according to the thermal measuring principle of a hot-film anemometer. Heat is drawn out of a heated body by a gas circulating around it. This flow-dependent cooling is utilized as a measuring effect. Since the heat loss depends on the number of particles that hit the surface of the heated body, it is possible to directly determine the mass flow rate. This means there is no need for pressure and temperature influences to be compensated.

The calibration of the devices is done on a highly precise flow test machine with air as calibration medium. For standard biogas applications, the calibration data are subsequently converted, whereby a medium gas composition is based on 53 Vol% methane, 45 Vol% carbon dioxide and 2 Vol% air. Devices for applications that clearly deviate from this gas composition must be ordered with a special calibration for biogas. In this case, the exact gas composition is to be specified with the order.

The measuring systems of the FMT200-D series consist of the following components:

- Flowmeter sensor and
- Pipe component of various types.

2.1 Pipe components

Pipe components for nominal diameters 1 ... 3" are available in various designs. In addition it is possible to integrate the flowmeter sensor directly into pipes of DN 100 ... DN 250 (4 ... 6") or into pipes with non-circular cross-sections using a weld-on adapter.

The pipe components and weld-on adapters guarantee the defined installation of the transducer in the pipeline. Moreover, they allow simple removal and installation of the transducer for inspection and/or cleaning. By closing the pipe component with a blind flange, it is possible to use the measuring section even without installed transducer.

The versions available as standard - depending on the respective nominal diameter and the desired adaptation - are shown in chapter 8 Specifications.

2.2 Flowmeter sensor

The flowmeter sensor designed as a plug-in unit contains, besides the sensor unit, the sealed-in transmitter circuitry accommodated in the sensor head. The circuitry mainly consists of the differential temperature control unit for the sensor elements, a memory for all parameters that are specific to the measuring point, a connector for the LCI adapter, and the computing power for creating flow-dependent data records.

In addition, a flow-linearized analog signal of 0/4...20 mA (electrically isolated) is directly provided. No special supply/evaluation device is required. The flowmeter sensor is installed in the pipe component as a plug-in unit with a centering pin in a defined manner. See chapter 8 Specifications.

3 Mounting

3.1 Recommended steadying lengths according to DIN EN ISO 5167-1

<p style="text-align: right;">G01023</p>	
<p style="text-align: center;">G01024</p>	<p>Expansion X = 0</p>
<p style="text-align: center;">G01025</p>	<p>Reduction X = 0</p>
<p style="text-align: center;">G01026</p>	<p>90° manifold X = 5</p>
<p style="text-align: center;">G01027</p>	<p>Two 90° manifolds at the same level X = 10</p>
<p style="text-align: center;">G01028</p>	<p>Two 90° manifolds at two levels X = 25</p>
<p style="text-align: center;">G01029</p>	<p>Valve / gate X = 35</p>

To achieve the stated measuring accuracy, the steadying lengths seen above must be provided. For combinations of inlet run disturbances, e. g. valve and reducer, you must always consider the longer inlet run length. In confined spaces at the mounting location the outlet run length can be shortened to 3 x D. The reduction of the minimum inlet run length, however, will impact on the achievable accuracy.

High repeatability of the measuring value is still provided. Under certain circumstances, special calibration can be performed for insufficient steadying lengths. For this purpose and in individual cases consulting is necessary.

For gases with extremely low density (hydrogen, helium) the steadying lengths must be doubled.

3.2 Verifying the conditions



IMPORTANT (NOTE)

Before installing and commissioning the device, thoroughly read the operating instructions and observe the following instructions.

For each measuring system a calibration certificate is delivered which contains all the key information such as the measuring medium, measuring range, nominal diameter, serial number and order number.

Especially observe the following:

- The operating conditions of the measuring point must fully comply with the specification in the calibration certificate, such as the permissible measuring medium, operating temperature, operating pressure, measuring range, etc.
- Observe the permissible ambient temperatures.
- Correctly install the pipe component or weld-on adapter. Observe the flow direction!
- Ensure compliance with the recommended inflow/outflow sections
- Correctly mount the flowmeter sensor to the pipe component.
- Correctly install all gaskets and check them for perfect condition.
- Correctly install all electrical connections.

3.3 Selecting the installation site

- The installation site must fulfill the requirements stated in the chapter “Technical Data: Environmental Conditions”.
- In order to prevent the measuring accuracy from being affected, the appropriate inlet and outlet sections must be provided. These steadying lengths ensure that any disturbances of the flow profile are eliminated before reaching the actual measuring point at the flowmeter sensor.
- Provide straight, undisturbed pipes for steadying. The lengths of these pipes depends on the type of disturbance on the inlet side (see chapter 3.1).
- Components affecting the flow like valves or shut-off devices should be installed on the outlet side, i. e. downstream of the measuring point.
- When using a weld-on adapter to install the flowmeter sensor, observe chapter 9.2.

Make sure that all installed devices can be accessed easily.

3.4 Installing the flowmeter sensor and pipe components

The installation is described using the example of a pipe component. The description analogously also applies to the installation using a weld-on adapter.

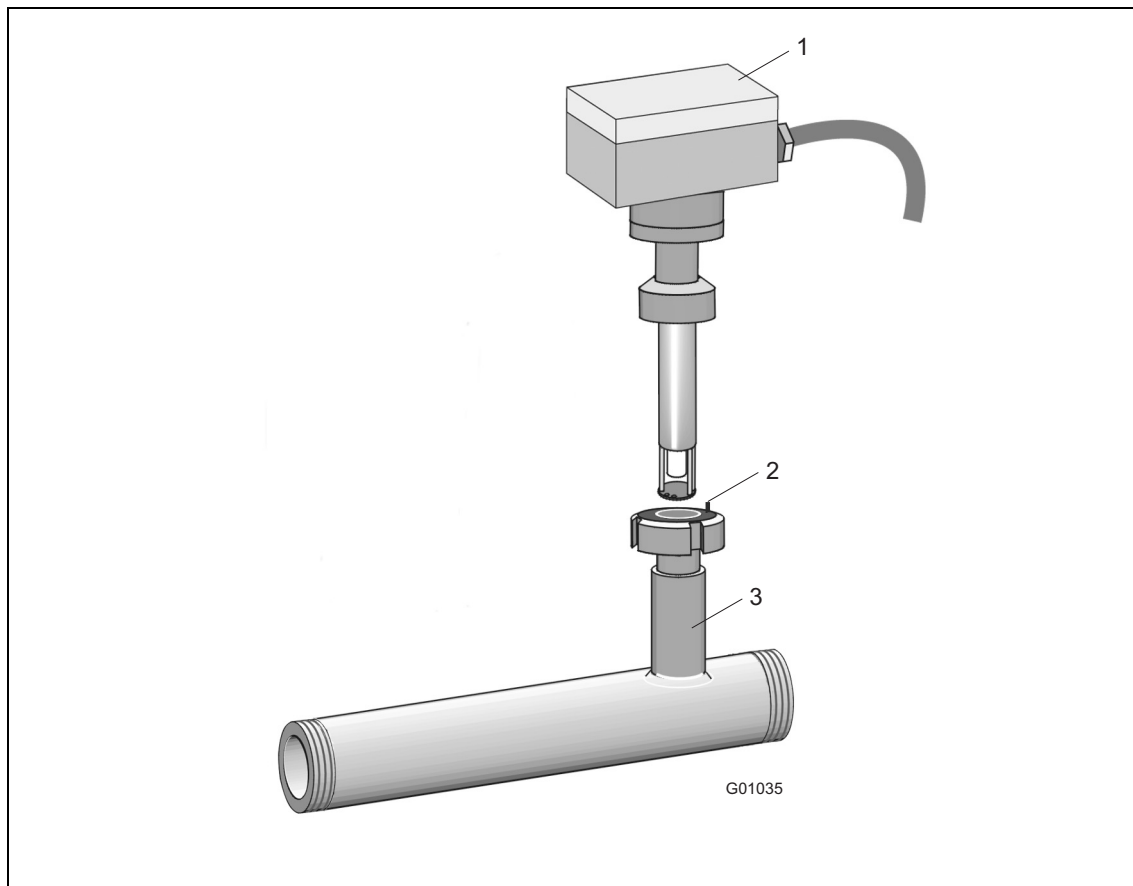

Fig. 3: Schematic representation of the pipe component with external thread

- 1 Flowmeter sensor
- 2 Centering pin, outflow side
- 3 Pipe component

- The flow direction must correspond to the arrow indicated on the pipe component.
- The gaskets used must not alter the cross-section of the opening in the pipeline and must ensure complete tightness once the flowmeter sensor and pipe component have been installed.
- The centering pin on the pipe component or weld-on adapter must be located on the outlet side downstream of the measuring point.
- Check the supplied gasket G according to DIN 11851 between the transducer and the pipe component / weld-on adapter for signs of damage prior to installation.
- When using flange-type pipe components all flange screws must be installed properly.
- Connecting threads are to be connected with the pipelines of the system using suitable sealant. All screw connections are to be checked for tightness.

Mounting

3.5 Weld-on adapter for Sensyflow FMT200-D

Length of weld-on adapter at delivery: L = 117 mm (4.6").

For outer pipe diameter 100 ... 150 mm (4 ... 6")

Prior to welding the weld-on adapter must be shortened to the appropriate length so that it has the length L after welding. This results in a measuring position in the middle of the pipeline.

$$L = H1 - 1/2 \times \text{Ø } D_{\text{outer}} \quad \text{with } H1 = 120 \text{ mm (4.72")}$$

For outer pipe diameter 150 ... 250 mm (6 ... 10")

Shorten the weld-on adapter in such a way that the fixed length L = 45 mm (1.77") is achieved after welding. As a result, the measuring position is not in the middle of the pipeline. For a correct calibration it is therefore mandatory to specify the exact inside diameter and wall thickness of the pipe in mm when ordering.

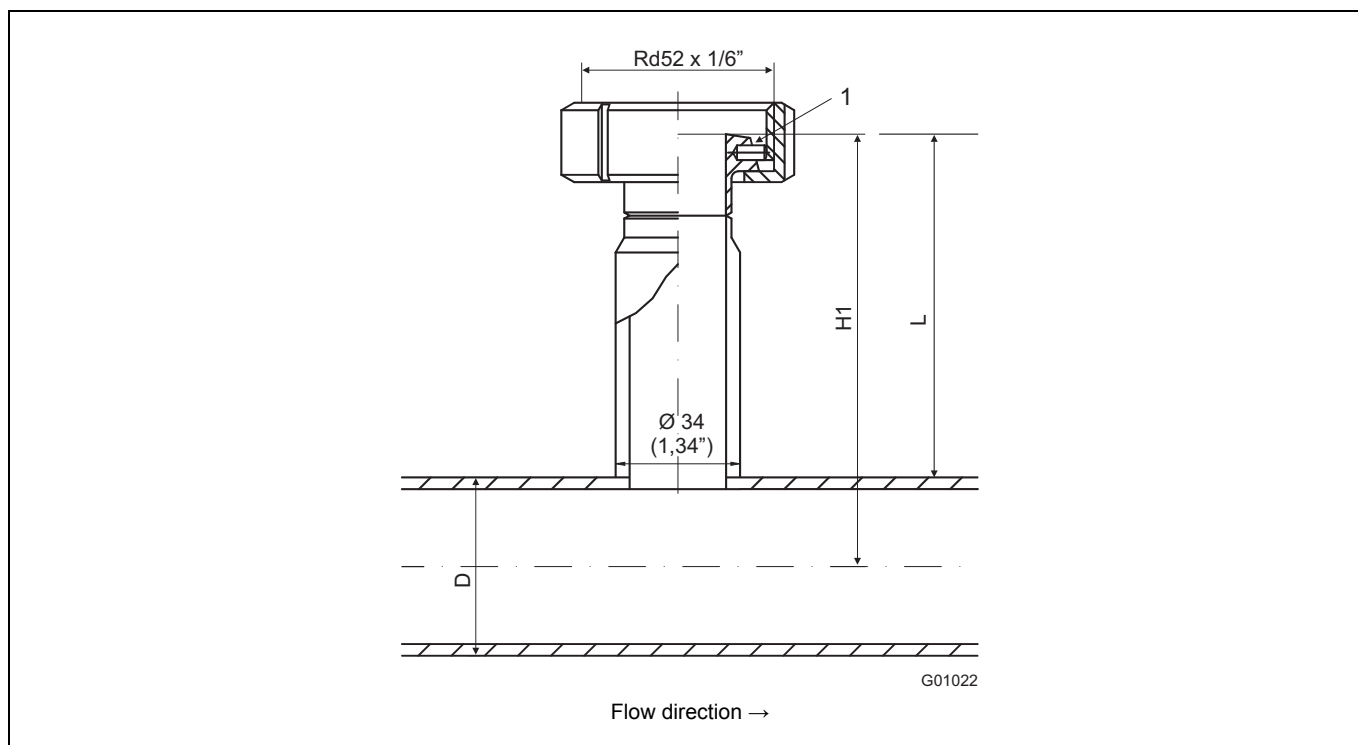

Fig. 4: Weld-on adapter DIN 11851 with lock nut. Dimensions in mm (inch)

1 Centering pin

i

IMPORTANT (NOTE)

Always mount the weld-on adapter together with the lock nut to the pipeline. Mounting it at a later time is not possible.

Observe thickness of pipeline wall and degree of shrinkage when welding on.

It is essential to maintain a right angle to the pipe axis (max. tolerance: 2°).

The adapter centering pin must be exactly aligned with the pipe axis in the flow direction (outflow side, behind the measuring point).

Once welding is complete, there must be a passage of at least 28 mm (1.10 inches) free for the purpose of mounting the flowmeter sensor; drill to create if necessary.

For outer pipe diameter 100 ... 150 mm (4 ... 6") The distance H1 from the upper edge of the adapter to the the pipe central axis must be within a tolerance of ± 2 mm (0.08").



Fig. 5: Weld-on adapter mounted to pipeline, centering pin right (outflow side)

4 Electrical connections

The device must have been installed before the electrical cables are connected. The supply power must be switched off.

Once the steps described below have been completed, the device is ready to be put into operation.

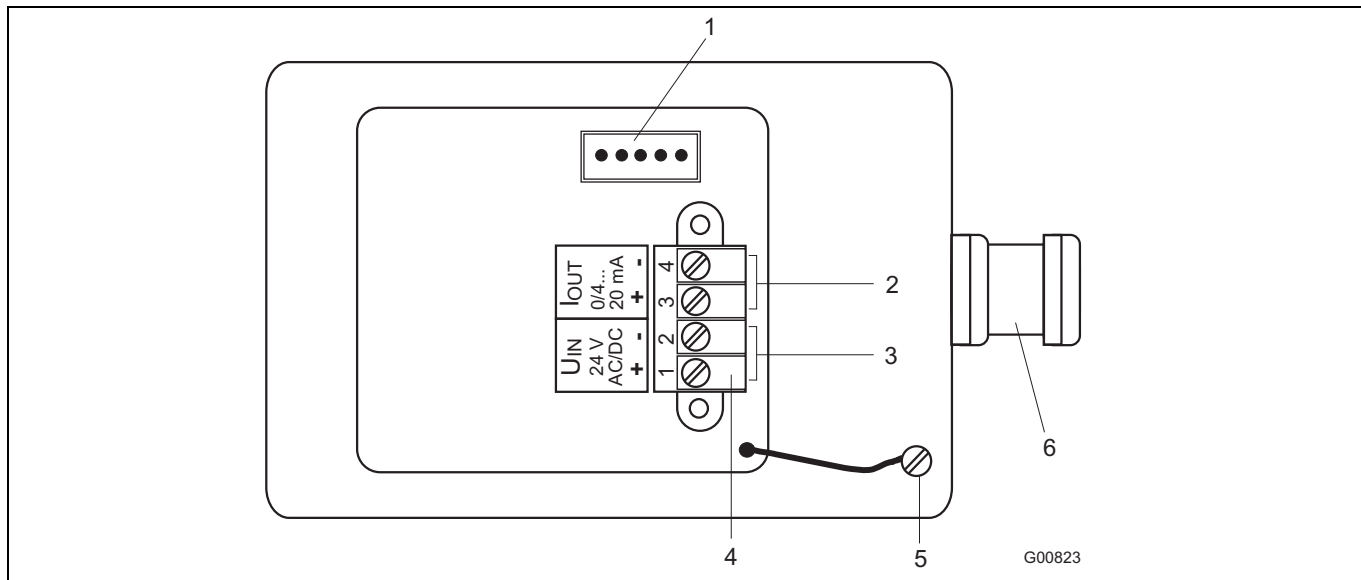

Fig. 6

- | | |
|---|---------------|
| 1 Socket for LCI adapter | 4 Terminals |
| 2 Analog output 0/4 ... 20 mA (electrically isolated) | 5 Ground |
| 3 Power supply 24 V AC/DC | 6 Cable entry |

1. A shielded, four-core cable (e.g., 4 x 1 mm²) must be used to connect the flowmeter sensor.
2. Release the four screws on the connection head cover of the flowmeter sensor and remove the cover.
3. Connect the four cores to the terminals of the flowmeter sensor electronics.



NOTICE - Potential damage to parts!

Electrical isolation is only ensured if terminal 4 is not connected to terminal 2 of the supply power.

4. Attach the shielding to the EMC cable entry.



IMPORTANT (NOTE)

If the shielding is routed directly into the housing, it will not have the desired effect (shielding effect will be lost).

5. Attach the connection head cover and screw it tight.
6. Check that the gasket is seated properly.

5 Commissioning

The device may only be started up / opened by qualified operating personnel. The device must be installed and the electrical signal lines must be connected prior to start-up.

5.1 Checking the installation

Prior to start-up, check that the equipment has been installed correctly:

- Is the device securely fastened?
- Have all the electrical signal, control and interface cables been laid and connected correctly?

5.2 Connecting the power supply

Step	Action
1.	Check whether the voltage specified on the name plate matches the line voltage.
2.	Use a supply power line with sufficient dimensions and ratings (circuit breaker).
3.	Connect the supply line to the supply power.



WARNING

When connecting the supply power, the information provided below must be observed. Failure to observe the information provided can result in severe injuries or death.



IMPORTANT (NOTE)

In the case of 24 V UC supply power, the device may only be supplied with a safely isolated low voltage (DIN VDE 0106).

Under no circumstances must the line voltage (115 V AC or 230 V AC) be connected to the 24 V UC input. Doing so would damage the device electronics beyond repair.

5.3 Switching on



WARNING

Before switching the device on, check that all the tasks described in the previous sections have been carried out correctly. Failure to observe the information provided can result in severe injuries or death.

Check again to ensure that the set operating voltage matches the supply power voltage.



WARNING

Switching the device on while the rear housing cover is open can result in an electric shock; in potentially explosive atmospheres, there is an additional risk of explosion. This can result in severe injuries or death. Only switch on the supply power when the housing cover is closed.

Switching on the supply power

Once the supply power has been switched on, the device starts to run automatically.

6 Parameterization

The configuration of the mass flowmeter can be changed with the aid of an LCI (local communication interface) adapter that has to be connected to the parameterization socket. This adapter is available as a separate accessory and comes supplied together with the relevant software.

The following parameters can be modified or read in:	
Read device data	Show current settings
Measurement range	Selection within the calibrated measurement range
Low flow	Low flow suppression 0...20 % of the upper range limit
Filter factor	Attenuation, 1 ... 500 can be selected (default: 50)
Output in the event of an error	Minimum (lower than 3.5 mA) or maximum (greater than 22.5 mA)
Analog output	0 / 4 ... 20 mA
Save modified data	Save settings
Factory setting	Select default setting
Status	Check function
Reset	Restart
Print out	Print out current settings
Password	For service technicians only

To activate the configuration changes, the device must be restarted. To do so, use the command "restart reset" or briefly interrupt the power supply for approximately 10 seconds.

7 Error messages

If failures occur (e.g., sensor wire break), the 0/4 ... 20 mA output will adopt the configured control value.

In the event of an error, the following settings can be made:

- Minimum < 3.5 mA
- Maximum > 22.5 mA



IMPORTANT (NOTE)

Default preset in case of a fault

Maximum 0 ... 20 mA

Minimum 4 ... 20 mA

These settings can be modified using the LC interface and the corresponding configuration software.

Other error messages can be read out via the "status" function ("check function", section 6).

8 Specifications

Measuring ranges

Nominal diameter	Maximum measuring ranges for air/nitrogen				
	kg/h	Nm ³ /h ¹⁾	NI/(min ²⁾)	lb/h	SCFM
1"	165	125	2100	360	70
1 1/2"	430	330	5500	940	190
2"	740	570	9500	1600	330
3"	1775	1375	22800	3900	800
6"	7500	5800	97000	16500	3400

Nominal diameter	Maximum measuring ranges for standard biogas				
	kg/h	Nm ³ /h ¹⁾	NI/(min ²⁾)	lb/h	SCFM
1"	130	95	1600	280	55
1 1/2"	310	260	4300	680	150
2"	510	390	6500	1120	230
3"	1200	920	15000	2640	540
6"	5700	4400	73000	12500	2500

- 1) Notation also m³/h - qn
 2) Notation also l/min - qn

All volume flow rate specifications are referenced to 0 °C / 1013.25 hPa (32 °F/14.696 psi).

Output

Analog output signal

0/4 ... 20 mA, switchable

Load

< 750 Ω, electrically isolated

Characteristics

Measurement deviation

Air, nitrogen < 1.5 % of rate plus ± 0.05 % of end value
 Biogas < 1.8 % of rate plus ± 0.1 % of end value
 under calibration conditions in specified flow range

Reproducibility

< ± 0.25 % of rate, t_{meas} = 10 s

Response time

T₆₃ ≈ 500 ms

Influences

Temperature effect

< 0.05 % / K of measured value

Pressure effect

± 0.2 % / 100 kPa (bar [14.5 psi]) of measured value

Pressure drop

< 1 kPa (10 mbar [0.145 psi]) at full scale
 decreasing quadratically for smaller flow rates

Ambient conditions

Ambient temperature for flowmeter sensor

-25 ... 70 °C (-13 ... 158 °F)

Ingress protection

IP 65, NEMA 4X

Storage temperature

-25 ... 85 °C (-13 ... 185 °F)

Measured medium conditions

Measured medium temperature, operating temperature

-25 ... 150 °C (-13 ... 302 °F)

Measured medium pressure, maximum

Standard 1 MPa (10 bar [145 psi])

Construction

Weight in kg (lbs)

Nominal diameter	Threaded pipe component		Flange pipe component	
	kg	(lbs)	kg	(lbs)
1"	1.5	3.3	5.6	12.3
1 1/2"	3.0	6.6	8.4	18.5
2"	5.5	12.1	11.0	24.3
3"	9.5	20.9	19.0	41.9
Weld-on adapter incl. lock nut	kg (lbs)			
	0.5	1.1		
Flowmeter sensor	kg (lbs)			
	1.8	4.0		

Materials, process connection

Flowmeter sensor CrNi steel, e.g. 1.4301

Pipe component with external threads

R 1" ... 3" Galvanized steel

Pipe component with connection flanges

DN 25 ... DN 80 CrNi steel, e.g. 1.4301

Weld-on adapter

CrNi steel, e.g. 1.4301

Connection flanges to EN1092-1 Form B1, PN10

Supply power

Voltage

24 V AC / DC ± 25 %

Power consumption

< 15 W

Power consumption

< 600 mA, recommended fuse of at least 2 A, slow-blow
 Cable gland M20 x 1.5

Communication interface

LCI adapter

Accessories (optional)

- Power supply unit
- Display unit
- Integrator with indicator (current pulse transformer)

Parameterize

The output signal of the Sensyflow FMT200-D flowmeter can be toggled between 0 ... 20 mA and 4 ... 20 mA. Additionally, a measuring range window can be expanded in such a way that a smaller span corresponds to a 20 mA current signal. A current < 3.5 mA or > 22 mA can be selected for the failure signal.

An LCI adapter is used to parameterize the device. It is possible to change the output signals or the settings of the measuring ranges and signals by using a standard PC or laptop.

Dimensions

9 Dimensions

9.1 Pipe component

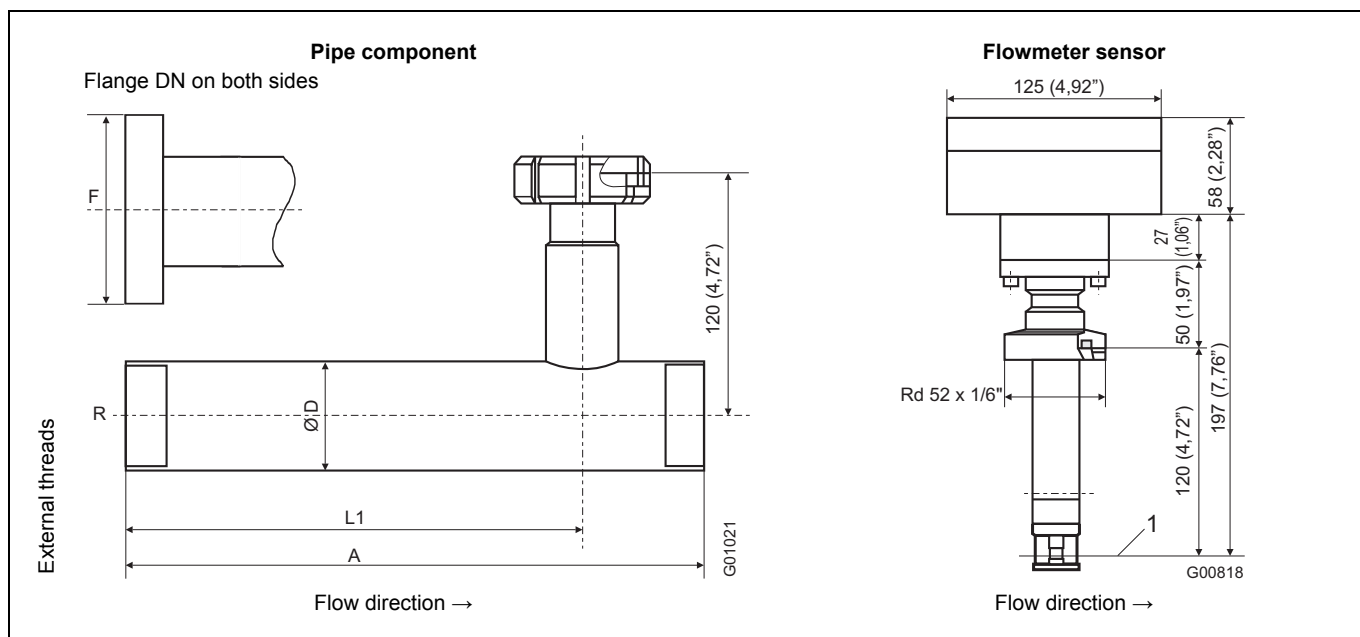

Fig. 7: Dimensions in mm (inch)

1 Middle of pipe component

DN	A	L1	Ø D interior	External threads R	Flange F
25 (1")	550 (21.65")	410 (16.14")	27.3 (1.07")	R1": 33.7 x 1.2	115 (4.53")
40 (1 1/2")	820 (32.28")	615 (24.21")	41.9 (1.65")	R1 1/2": 48.3 x 3.2	150 (5.91")
50 (2")	1080 (42.52")	810 (31.89")	53.9 (2.12")	R2": 60.3 x 3.2	165 (6.50")
80 (3")	1600 (62.99")	1200 (47.24")	79.9 (3.15")	R3": 88.9 x 4.5	200 (7.87")

Dimensions in mm (inch)

9.2 Weld-on adapter for Sensyflow FMT200-D

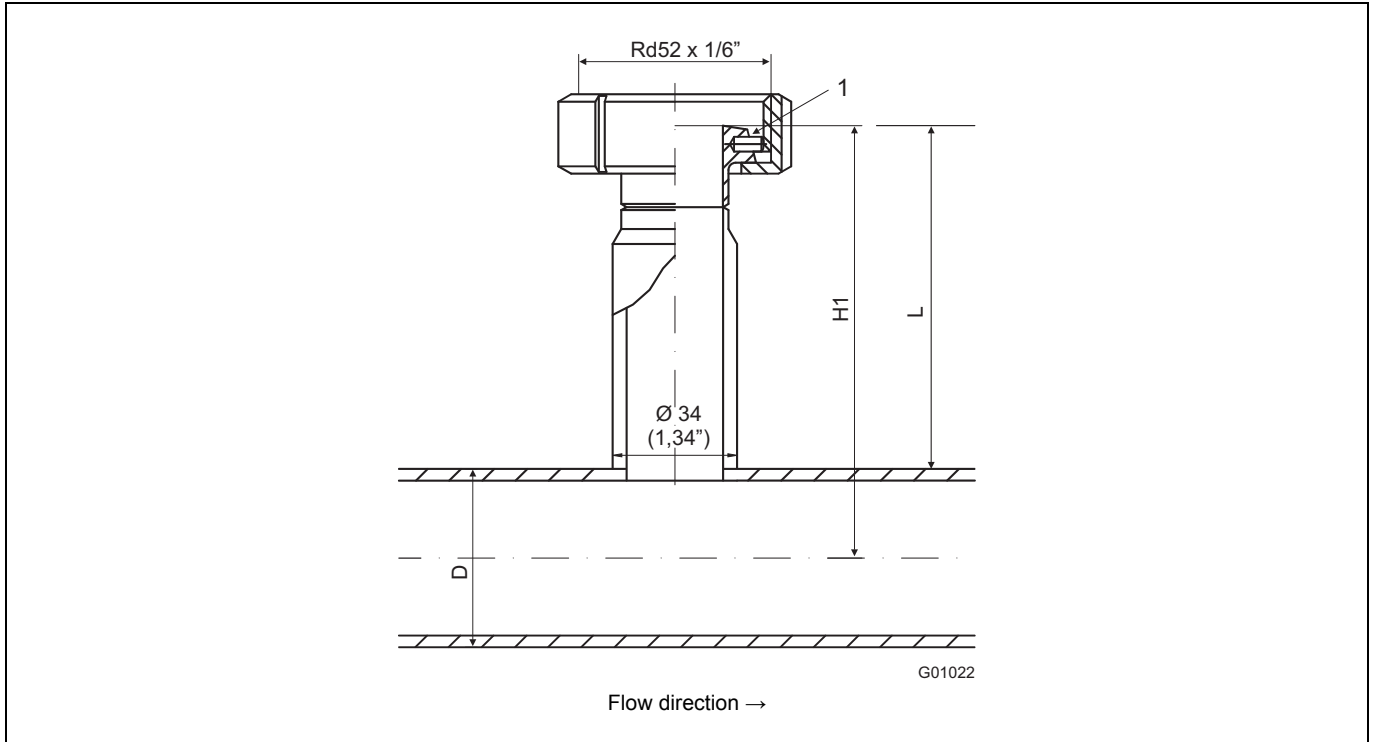

Fig. 8: Weld-on adapter DIN 11851 with lock nut. Dimensions in mm (inch)

1 Centering pin

Length of weld-on adapter at delivery: L = 177 mm (4.6").

D	L	H1
100 ... 150 mm (4 ... 6")	$H1 - 1/2 \times \text{Ø } D_{\text{outer}}$	120 mm (4.72")
150 ... 250 mm (6 ... 10")	45 mm (1.77")	variable ¹⁾

1) As a result, the measuring position is not in the middle of the pipeline

10 Appendix

10.1 Decommissioning and packaging



Packaging the device ready for transport or return to the manufacturer

If the original packaging material is no longer available, wrap the device in bubble wrap or corrugated cardboard and place it in a box of sufficient size lined with a shock-absorbing material (e.g., foam rubber). The thickness of the padding should be appropriate for the device weight and type of shipment. The box must be handled with care and labeled accordingly.

For overseas shipment, always add a desiccant (e.g., silica gel) and hermetically seal the device plus desiccant in a layer of polythene that is 0.2 mm thick. Use an amount of desiccant that is appropriate for the packing volume and the expected transport time (at least sufficient for 3 months). You should also line the box with a layer of union paper.

All devices returned to the manufacturer must be accompanied by a completed and signed decontamination certificate (see Appendix). Without this, ABB will not be able to process the return.

10.2 Approvals and certifications

CE mark		The version of the meter in your possession meets the requirements of the following European directives: <ul style="list-style-type: none"> - EMC directive 2004/108/EC - ATEX directive 94/9/EC
Explosion Protection		Identification for intended use in potentially explosive atmospheres according to: <ul style="list-style-type: none"> - ATEX directive (marking in addition to CE marking)
Calibration		DAkkS- / ILAC-accredited calibration equipment D-K-15081-01-00 <ul style="list-style-type: none"> - Example certificate



IMPORTANT (NOTE)

All documentation, declarations of conformity and certificates are available in ABB's download area.

www.abb.com/flow



EC Declaration of conformity

ABB Automation Products GmbH
 Dransfelder Str. 2
 37079 Göttingen



declares, that the following products

Type:

- pipe component for Sensyflow FMT400-VTS and FMT500-IG

Designation		FMT081-A(/B/C/D)-	Prototype-certification
Design 1 Wafer flange version with standard adapter	DN 40...200 / PN40 ANSI 1½" ... 8" / 150lbs ANSI 1½" ... 8" / 300lbs	1C1A3...1L1A3 1C2A3...1L2A3 1C3A3...1L3A3	ISD-22-09-0203
Design 1 Wafer flange version with Ball valve	DN 40...200 / PN40 ANSI 1½" ... 8" / 150lbs ANSI 1½" ... 8" / 300lbs	1C1G3...1L1G3 1C2G3...1L2G3 1C3G3...1L3G3	ISD-22-09-0203
Design 1 Wafer flange version with hot tap fitting	DN 50...125 / PN16 DN 150...200 / PN16 ANSI 2" ... 5" / 150lbs ANSI 6" ... 8" / 150lbs	1D1H3...1H1H3 1J1J3...1L1J3 1D2H3...1H2H3 1D2J3...1H2J3	ISD-22-09-0205
Design 2 Partial Measuring Section with standard adapter	DN 40...80 / PN40 ANSI 1½" ... 2" / 150lbs ANSI 1½" ... 2" / 300lbs	2C1A3...2F1A3 2C2A3...2D2A3 2C3A3...2D3A3	ISD-22-09-0204
Design 2 Partial Meas. Sect. + FS with standard adapter	DN 40...80 / PN40 ANSI 1½" ... 2" / 150lbs ANSI 1½" ... 2" / 300lbs	3C1A3...3F1A3 3C2A3...3D2A3 3C3A3...3D3A3	ISD-22-09-0204

Postanschrift:
 Dransfelder Str. 2
 D-37079 Göttingen

Besuchsanschrift:
 Dransfelder Str. 2
 D-37079 Göttingen
 Telefon +49 551 905 0
 Telefax+49 551 905 777
 Internet: <http://www.abb.com/de>

Sitz der Gesellschaft:
 Ladenburg
 Registergericht:
 Amtsgericht Mannheim
 Handelsregister:
 HRB 700229
 USt-IdNr.: DE 115 300 097

Vorsitzender des Aufsichtsrats:
 Hans-Georg Krabbe
 Geschäftsführung
 Til Schreier

Bankverbindung:
 Commerzbank AG Frankfurt
 Konto: 589 635 200
 BLZ: 500 400 00



➤ pipe component for Sensyflow FMT400-VTCS

Designation		FMT082-A/(B)-	Prototype-certification
Pipe component with screw connection S	NW 40...80 / PN16	0B6A4...0D6A4	ISD-22-09-0204
Pipe component with flange FG	NW 40...80 / PN10	0B8A5...0D8A5	ISD-22-09-0204

➤ pipe component for Sensyflow FMT200-D

Designation		V14223-xx-	Prototype-certification
Pipe Component with threads	NW 1½" ...3" / PN10	2...4	ISD-22-09-0204
Pipe component with flange	NW 40...80 / PN10	B...D	ISD-22-09-0204

are complying with the requirements of the European directive:
97/23/EC Pressure equipment directive

Application:

pipng and piping accessories category I, II and III,
for gases, group 1 and 2

The conformity assessment has been subjected to the following procedure:

EC type examination (B) and
production quality assurance (D)

Applied standards and technical specification:

AD 2000 technical rules

Monitoring of quality management system and of manufacturing is performed by:

TÜV NORD Systems GmbH & Co KG – notified body no. 0045

ABB Automation Products GmbH

Göttingen, 30.11.2010

ppa. Klaus Halbfas, plant management

Page 2 of 2

Postanschrift:
Dransfelder Str. 2
D-37079 Göttingen

Besuchsanschrift:
Dransfelder Str. 2
D-37079 Göttingen
Telefon +49 551 905 0
Telefax+49 551 905 777
Internet: <http://www.abb.com/de>

Sitz der Gesellschaft:
Ladenburg
Registriergericht:
Amtsgericht Mannheim
Handelsregister:
HRB 700229
USt-IdNr.: DE 115 300 097

Vorsitzender des Aufsichtsrats:
Hans-Georg Krabbe
Geschäftsführung:
Till Schreiter

Bankverbindung:
Commerzbank AG Frankfurt
Konto: 589 635 200
BLZ: 500 400 00

BZ – 25 - 0012 Rev. 01 No. 16353



EG-Konformitätserklärung
EC-Certificate of Compliance



Hiermit bestätigen wir die Übereinstimmung der aufgeführten Geräte mit den Richtlinien des Rates der Europäischen Gemeinschaft, welche mit dem CE- Zeichen gekennzeichnet sind.

Die Sicherheits- und Installationshinweise der Produktdokumentation sind zu beachten.
We herewith confirm that the listed devices are in compliance with the council directives of the European Community and are marked with the CE- marking. The safety and installation requirements of the product documentation must be observed.

Hersteller:
Manufacturer: ABB Automation Products GmbH,
 Dransfelder Straße 2, 37079 Göttingen - Germany

Gerät:
Device: Thermischer Massen Durchflussmesser
 Thermal Mass Flowmeter

Modelle.:
Models: Sensyflow FMT400-VTS
 Sensyflow FMT400-VTCS
 Sensyflow FMT200-D

Produktnummer:
Models: V14222-...
 V14223-...

Richtlinie:
Directive: 2004/108/EG * (EMV)
 2004/108/EC * (EMC)

Europäische Norm:
European Standard: EN 61326-1, 10/2006 * EN 61326-2-3, 05/2007 *
 EN 61326-1, 10/2006 * EN 61326-2-3, 05/2007 *

Richtlinie:
Directive: - - -

Europäische Norm:
European Standard: - - -

* einschließlich Nachträge / *including alterations*

Göttingen, 01. Dezember 2011

i.V. Klaus Schäfer
 (QM Manager)

i.V. Dr. Günter Kuhlmann
 (R&D Manager)

BZ-13-5117
 Rev.01

ABB Automation Products GmbH

Postanschrift:
 Dransfelder Str. 2
 D-37079 Göttingen

Besuchsanschrift:
 Dransfelder Str. 2
 D-37079 Göttingen

Telefon +49 551 905 0
 Telefax+49 551 905 777
 Internet: <http://www.abb.com/de>



Calibration Certificate

for Characteristic No. 1

Customer Muster F-No. 123456789 X001
Serial-No. 00123456

Object of Calibration

Flowmeter Sensyflow FMT200-D Insertion Length/Version 120 mm
Supply Voltage 24 V AC/DC Output Signal 4...20mA
ID 33511801 Software Version V 2.5

Application Data

Gas Composition Volume%
Air 100.0
Inside Pipe Diameter 3 inch
Operating Temperature 0 ... 60 °C
Operating Pressure 1 ... 10 bar/abs.
Customer Measuring Range 0 ... 1800 kg/h
Maximum Measuring Range 0 ... 1800 kg/h
Standard Conditions 0 °C, 1013 mbar/abs.

Calibration

Best measurement capability of the testrig PS0051 U = 0,3% and PS0052 U = 0,4%.
The measurement standards used for the calibration (critically operated venturi nozzles) are traceable to the representation of the SI-units.

Test Stand DN80/Filter+15°D Testrig PS0052
Calibration Medium Air
Calibration Temperature 19.6 °C Calibration Pressure 994 mbar/abs.

With the calibration data the adaption to the customer application was performed.

Final Test

We herewith certify that the instrument mentioned above has been calibrated in air in accordance with DIN ISO 9001:2008.
The specifications according to the data sheet were fulfilled.

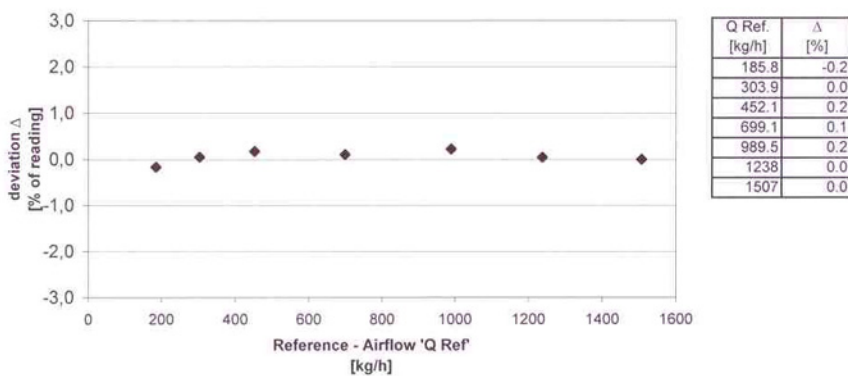

This certificate was generated automatically and is valid without signature.

37079 Göttingen, 04/05/2012

Inspector:

Statement on the contamination of devices and components

Repair and / or maintenance work will only be performed on devices and components if a statement form has been completed and submitted.

Otherwise, the device / component returned may be rejected. This statement form may only be completed and signed by authorized specialist personnel employed by the operator.

Customer details:

Company: _____

Address: _____

Contact person: _____

Telephone: _____

Fax: _____

E-mail: _____

Device details:

Type: _____

Serial no.: _____

Reason for the return/description of the defect: _____

Was this device used in conjunction with substances which pose a threat or risk to health? Yes No

If yes, which type of contamination (please place an X next to the applicable items)?

Biological Corrosive / irritating Combustible (highly / extremely combustible) Toxic Explosive Other toxic substances Radioactive

Which substances have come into contact with the device?

1. _____

2. _____

3. _____

We hereby state that the devices / components shipped have been cleaned and are free from any dangerous or poisonous substances.

Town/city, date_____
Signature and company stamp

ABB has Sales & Customer Support expertise in over 100 countries worldwide.

www.abb.com/flow

The Company's policy is one of continuous product improvement and the right is reserved to modify the information contained herein without notice.

Printed in the Fed. Rep. of Germany (06.2012)

© ABB 2012

3KXF421005R4201



ABB Limited

Oldends Lane, Stonehouse
Gloucestershire, GL10 3TA
UK

Tel: +44 (0)1453 826661
Fax: +44 (0)1453 829671

ABB Inc.

125 E. County Line Road
Warminster, PA 18974
USA

Tel: +1 215 674 6000
Fax: +1 215 674 7183
measurement@us.abb.com

ABB Automation Products GmbH

Dransfelder Str. 2
37079 Goettingen
Germany

Tel: +49 551 905-534
Fax: +49 551 905-555