

# EAS822 (Contrac) Power Electronic Unit



For continuous control of Contrac actuators  
PME120 AN and LME620 AN

Microprocessor-controlled power electronic unit with  
integrated frequency converter

Voltage supply 115 V AC or 230 V AC

Conventional signal interface (0 / 4 ... 20 mA / 24 V)

Digital communication via RS232 and HART

Additional functions such as process controller,  
maintenance computer, programmable characteristics

Rack installation, protection class IP 20

Torque and speed variation

Continuous positioning

Simple installation and commissioning

Simple configuration and parameter setting via graphical  
user interface

High response sensitivity

Reliable for short positioning times

## Contents

<b>1</b>	<b>Concept</b> .....	<b>3</b>
<b>2</b>	<b>Technical data</b> .....	<b>3</b>
2.1	General information.....	3
<b>3</b>	<b>Electrical connection</b> .....	<b>4</b>
<b>4</b>	<b>Dimensions</b> .....	<b>5</b>
4.1	Power Electronic Unit.....	5
<b>5</b>	<b>Ordering information</b> .....	<b>7</b>

## 1 Concept

Compact actuator for the operation of final control elements with preferably 90° rotary movement such as flaps, cocks, etc.

The torque is transferred via a lever / linkage bar assembly or the actuator is directly coupled to the cock flange.

A special power electronic unit controls the actuator. The electronic unit serves as the interface between actuator and control system.

During continuous positioning the power electronic unit varies the motor torque steplessly until the actuator force and the restoring

process forces are balanced. High response sensitivity and high positioning accuracy with short positioning time ensure an excellent control quality and a long actuator life.



### Important

The ANSI information appears in parentheses after the SI-information.

## 2 Technical data

Supply voltage	115 V AC (94 ... 130 V) or 230 V AC (190 ... 260 V); 47.5 ... 63 Hz; 1 Ph	
Power	50 W / 160 W	
External fuse for power electronic unit	16 A; time-lag	
External fuse Anti-condensation heater	2 ... 6 A; medium time-lag	
Analog input; setpoint	0 / 4 ... 20 mA	
Analog output; actual value	0 / 4 ... 20 mA, galvanically isolated	
3 binary inputs BE 1 ... BE 3 (DI 1 ... DI 3)	Binary 0: -3 ... 5 V or open, galvanically separated Binary 1: 12 ... 35 V, galvanically separated	
3 binary outputs BA 1 ... BA 3 (DO 1 ... DO 3)	Potential free relay contact, max. 60 V DC / 25 V AC, 150 mA	
Digital communication	RS232 for commissioning and service, optionally FSK / HART®	
Default settings	Behavior in 0 / 100 % end position: set point function: set point input: function selection: actual value: digital input:	Hold with rated torque / end positions linear, set point = position value 4 ... 20 mA positioner, parameter: setpoint 4 ... 20 mA BE 1 (DI 1) M / A selection; BE 2 / 3 (DI 2 / 3) manual intervention +/-
	digital output:	BA 1 (DO 1) ready for operation; BA 2 / 3 (DO 2 / 3) end position signal 0 / 100 %
Voltage output $U_V$	24 V, 15 mA, galvanically isolated ; e.g., for scanning external contacts	
Transmitter (optional)	Supply for 2-wire transmitter with activated process controller in Contrac	
Individual settings	See data sheet 10/68-2.40 or upon request	

### 2.1 General information

	Power Electronic Unit EAS822 (Contrac)
Protection Class	IP 20
Humidity	≤ 75 % annual average (condensation not permitted)
Rack inlet temperature	0 ... 45 °C (32 ... 110 °F)
Mounting position	Vertical, connections on right-hand side
Vibration stress	2 ... 9 Hz: max. deflection: 3 mm (0.12 inch) 9 ... 200 Hz: acceleration: 1 g
Coating	2-layer component epoxy (RAL 9005, black)
Electrical connection	Mains supply via terminals; others via pluggable terminals
Weight	Approx. 9 kg (20 lbs)

### 3 Electrical connection



**Important**

The electrical connection is provided by a plug on the actuator and the terminals on the electronic unit.

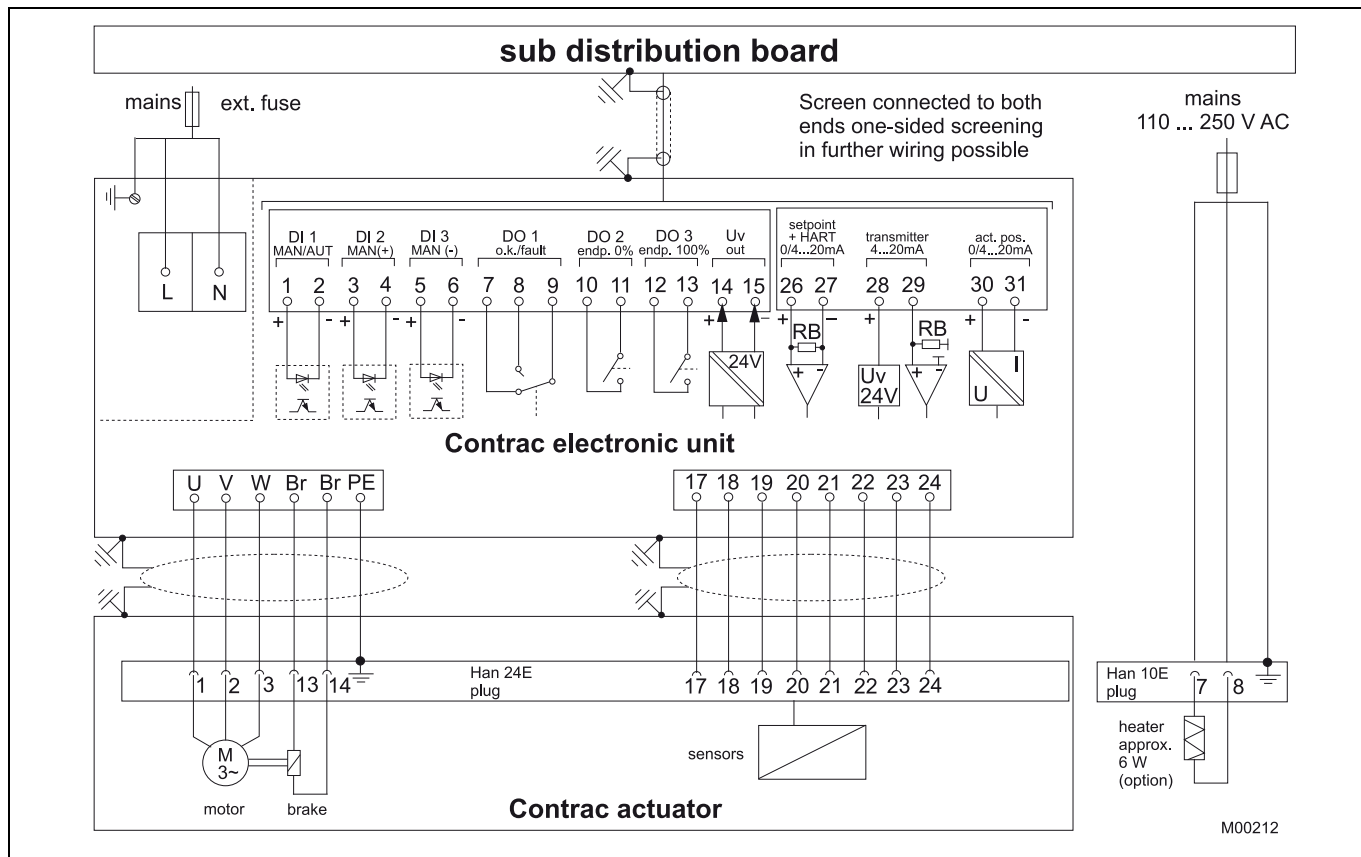

Fig. 1

## 4 Dimensions

### 4.1 Power Electronic Unit

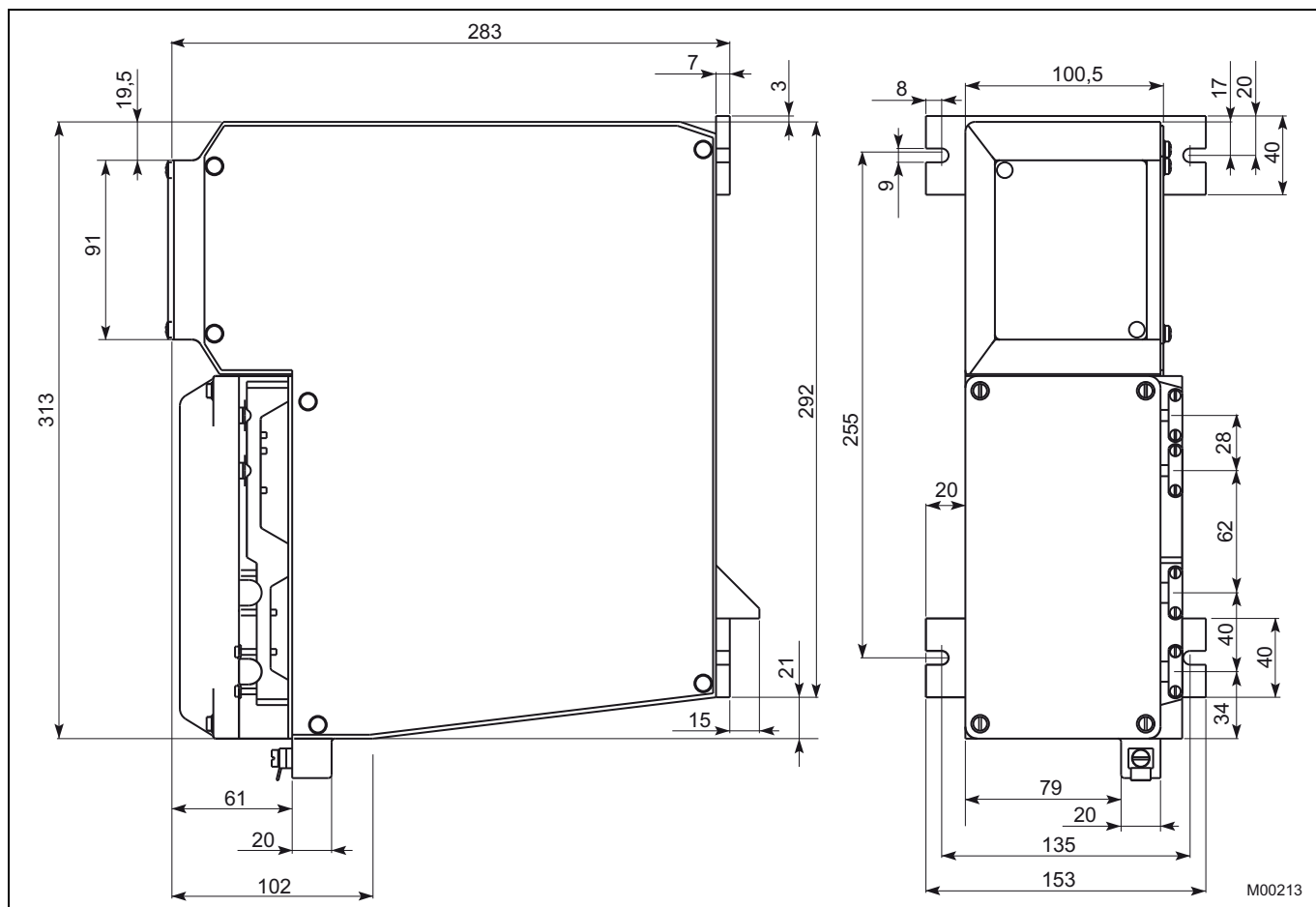

Fig. 2: Dimensions in mm

EAS822		
	Terminals	
	For cable Ø	Terminals for wire gauge
Mains cable	13 mm	max. 4 mm <sup>2</sup>
Signal cable (DCS)	8 mm	max. 1.5 mm <sup>2</sup>
Transmitter	8 mm	max. 1.5 mm <sup>2</sup>
Motor cable	13 mm	max. 4 mm <sup>2</sup>
Sensor cable	8 mm	max. 1.5 mm <sup>2</sup>

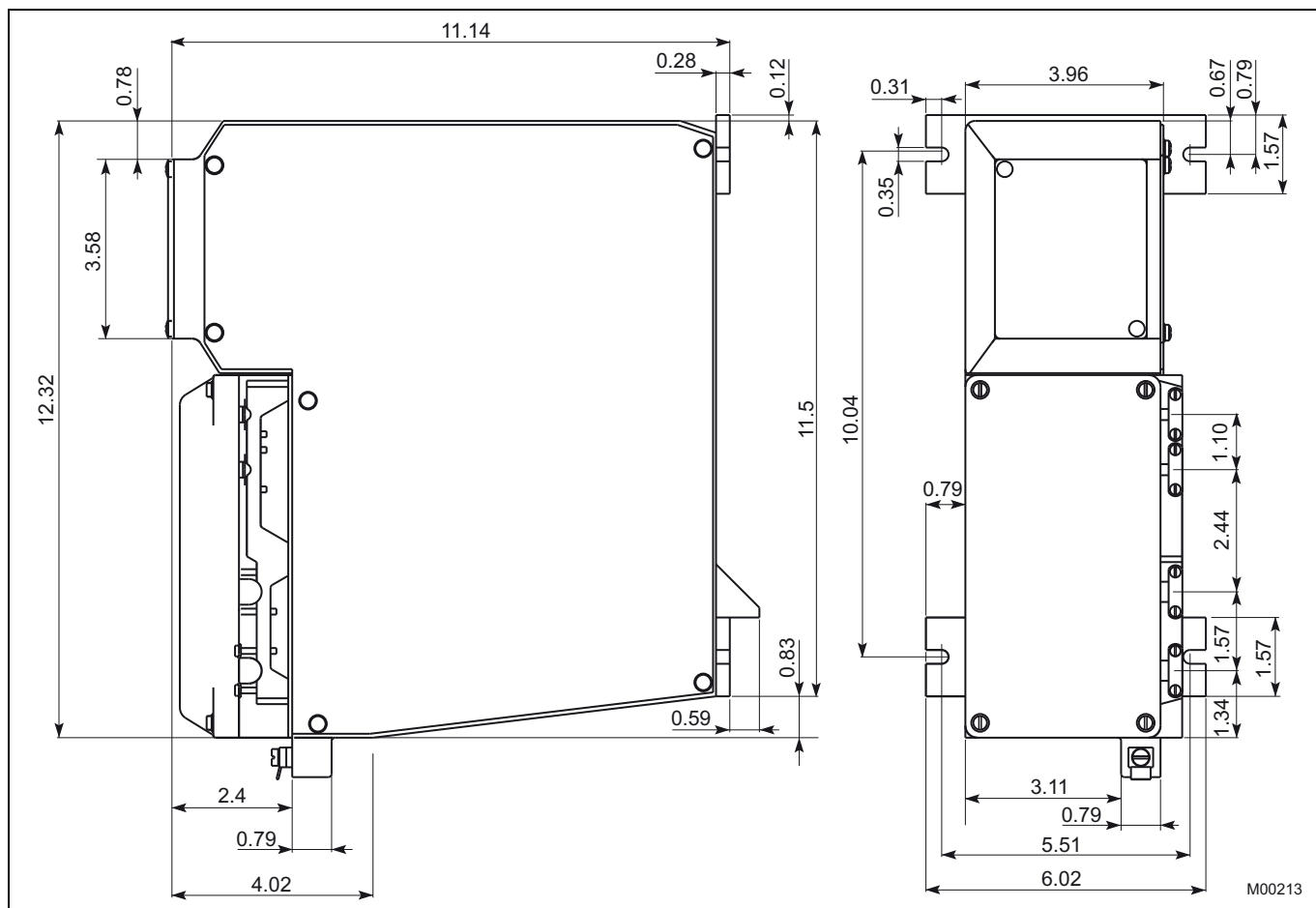

Fig. 3: Dimensions in inches

EAS822		
	Terminals	
	For cable Ø	Terminals for wire gauge
Mains cable	0.51 inch	max. 12 AWG
Signal cable (DCS)	0.31 inch	max. 16 AWG
Transmitter	0.31 inch	max. 16 AWG
Motor cable	0.51 inch	max. 12 AWG
Sensor cable	0.31 inch	max. 16 AWG

## 5 Ordering information

Electronic Unit		Variant digit No.		Code			
EAS822		1 - 8	9	10	11	12	
Suitable for		Catalog No. V68822A-					
Part-Turn Actuator PME120-AN				0	0	0	1
Linear Actuator LME620-AN				0	0	0	2
for PME120-AN							
<b>adjusted to:</b>	<b>Nm</b>	<b>(ft-lbs)</b>	<b>°/s</b>	<b>s/90°</b>			
	100	80	4.5	20		310	
	100	80	3.0	30		311	
	100	80	1.5	60		312	
	50	40	3.0	30		313	
	50	40	1.5	60		314	
for LME620-AN							
<b>adjusted to:</b>	<b>kN</b>	<b>(lbs)</b>	<b>mm/s</b>	<b>s/60 mm</b>	<b>(s/in)</b>		
	4	900	2.0	30	12.7	320	
	4	900	1.0	60	25.4	321	
	4	900	0.5	120	50.8	322	
<b>Special features of Electronic Unit</b>							
Select at least one feature per group							
<b>Supply voltage</b>	230 V AC 1 Ph					380	
	115 V AC 1 Ph					381	
<b>Frequency</b>	50 Hz					382	
	60 Hz					383	
<b>Digital communication</b>	RS 232					384	
	RS 232 + HART					385	
<b>Ambient temperature range of actuator</b>	-10 ... 65 °C (15 ... 150 °F)					344	
	-25 ... 55 °C (-15 ... 130 °F)					343	
	-1 ... 85 °C (30 ... 185 °F) (only for PME120-AN, max. 2°/s)					349	
<b>Settings of electronic unit</b>	Standard settings (see techn. data)					390	
	Customer specific settings (see data sheet 10/68-2.40 EN)					391	

<b>Additional ordering information</b>		Code		
Anti-condensation heater in actuator "ON"		359		
Identification on data label (alphanumeric, max. 32 characters)		295		
Data label with US units		253		
F. No. of associated actuator on data label of electronic unit		297		
Factory certificate 2.1 acc. to EN 10204		291		
Certificate B acc. to EN 10204		292		
<b>Operating instruction</b>	(specify total quantity required, 1 copy without extra charge)			
German	(no specification for 1 copy)	Z1D		
English	(always state Code-No.)	Z1E		

# Contact us

## **ABB Ltd.**

### **Process Automation**

Salterbeck Trading Estate  
Workington, Cumbria  
CA14 5DS  
UK

Phone: +44 (0)1946 830 611

Fax: +44 (0)1946 832 661

## **ABB Inc.**

### **Process Automation**

125 E. County Line Road  
Warminster, PA 18974  
USA

Phone: +1 215 674 6000

Fax: +1 215 674 7183

## **ABB Automation Products GmbH**

### **Process Automation**

Schillerstr. 72  
32425 Minden  
Germany

Phone: +49 551 905-534

Fax: +49 551 905-555

[www.abb.com](http://www.abb.com)

## Note

We reserve the right to make technical changes or modify the contents of this document without prior notice. With regard to purchase orders, the agreed particulars shall prevail. ABB does not accept any responsibility whatsoever for potential errors or possible lack of information in this document.

We reserve all rights in this document and in the subject matter and illustrations contained therein. Any reproduction, disclosure to third parties or utilization of its contents - in whole or in parts - is forbidden without prior written consent of ABB.

Copyright© 2010 ABB

All rights reserved