

# RSD100 (ContraC) Electrical Linear Actuator

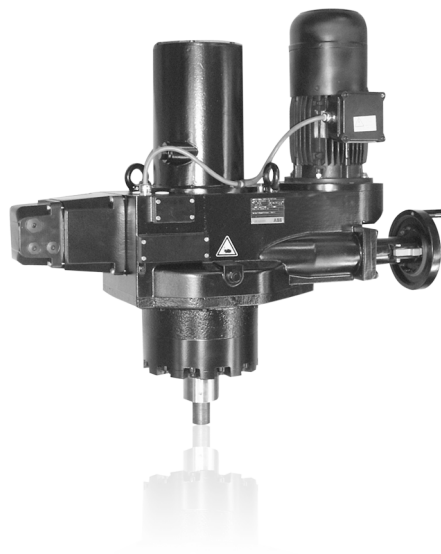

For continuous positioning,  
Rated force 100 kN (22500 lbf)

Electrical actuator for continuous positioning or step control

Stallproof without the need of position or torque dependent switch-off

Three-phase asynchronous motor

Sturdy gear unit with highly efficient design

Internal rotary-linear conversion

Hand wheel for emergency operation

Integrated sensors for position and temperature

Signal and power input only via process-controlled power electronic unit in separate field-mount housing

Voltage supply 115 V AC or 230 V AC only via special power electronics

---

## **Contents**

<b>1</b>	<b>Concept</b> .....	<b>3</b>
<b>2</b>	<b>Technical data</b> .....	<b>3</b>
2.1	Actuator .....	3
2.2	General information.....	3
2.3	24-pole plug on the actuator .....	4
2.4	Tapped holes for cable glands .....	4
<b>3</b>	<b>Electrical connection</b> .....	<b>5</b>
3.1	Power Electronic Unit EBN853 (Contrac) / EBN861 (Contrac).....	5
3.2	Power Electronic Unit EBS852 (Contrac) / EBS862 (Contrac) .....	7
<b>4</b>	<b>Dimensions</b> .....	<b>8</b>
4.1	Linear actuator .....	8
<b>5</b>	<b>Ordering information</b> .....	<b>10</b>

## 1 Concept

Compact actuator for the operation of final control elements with preferably linear movement. The actuator thrust rod transfers the force directly to the final control element.

A continuous power electronic unit controls the actuator. The electronic unit serves as the interface between actuator and control system.

During continuous positioning the power electronic unit varies the motor torque steplessly until the actuator force and the restoring

process forces are balanced. High response sensitivity and high positioning accuracy with short positioning time ensure an excellent control quality and a long actuator life.



### Note

The ANSI information appears in parentheses after the SI information.

## 2 Technical data

### 2.1 Actuator

Model	RSD100-1.5	RSD100-10,0
Rated force	100 kN (22500 lbf) (adjustable to 0.5 / 0.75 or 1x rated force)	
Starting force	1.2 x rated force (break-away torque in end positions for short time 2 x rated force)	
Operating speed, adjustable	0.1 ... 1.5 mm/s (254 ... 17 s/inch)	0.1 ... 10.0 mm/s (254 ... 2.5 s/inch)
Stroke	min.: 0 ... 25 mm (0 ... 0.98 inch) / max. 0 ... 150 mm (0 ... 5.9 inch) or min.: 0 ... 60 mm (0 ... 2.36 inch) / max. 0 ... 300 mm (0 ... 11.8 inch)	
Weight (150 mm stroke)	approx. 215 kg (474 lb)	approx. 242 kg (534 lb)
Weight (300 mm stroke)	approx. 275 kg (606 lb)	approx. 273 kg (602 lb)
Related electronics	For field installation: Model EBN853 <sup>1)</sup> For rack installation: Model EBS852 <sup>2)</sup>	For field installation: Model EBN861 <sup>3)</sup> For rack installation: Model EBS862 <sup>4)</sup>
Motor type	MC 90 BA	MC 112 BA
Sensors	Position and temperature sensor always available	

1) Data sheet EBN853: 10/68-8 27

2) Data sheet EBS852: 10/68-8 24

3) Data sheet EBN861: 10/68-8 22

4) Data sheet EBS862: 10/68-8 25

### 2.2 General information

RSD100	
Operating mode	S9; stallproof acc. to IEC 60034-1 / EN 60034-1
Protection Class	IP 66
Humidity	≤ 95% average; condensation not permitted
Ambient temperature	-10 ... 65° C (15 ... 150° F) -30 ... 50 °C (-20 ... 130 °F)
Mounting position	any position; preferably IMV 1; IMV 3; IMB 5 acc. to IEC 60034-7 / EN 60034-7 (other mounting positions available upon request)
Coating	2-layer component epoxy (RAL 9005, black)
Anti-condensation heater (optional)	Motor winding: Directly from the electronic unit Signal space: Separate heating resistor; separate power supply or power feed from Contrac electronic unit
Electrical connection	plug with crimp snap-in contacts or terminals connecting cable electronics – actuator optional (see ordering information of electronics)
Power supply for motor and sensors	Only via Contrac electronic unit (refer to the data sheet for the electronic unit)

### 2.3 24-pole plug on the actuator

	<b>Crimp pins</b>	<b>Terminals (Option)</b>
Cable gauge	Motor, heater: 1.5 mm <sup>2</sup> (16 AWG) Signals: 0.5 mm <sup>2</sup> (20 AWG)	2.5 mm <sup>2</sup> (14 AWG)
Contact surface	Gold-plated	Motor, signal: Gold-plated Heater: Silver-plated

### 2.4 Tapped holes for cable glands

<b>Tapped holes for cables</b>	<b>optional adapters*</b>	
M20 x 1.5 (2x)	PG 16 (2x)	NPT ½" (2 x)
M25 x 1.5 (1 x)	PG 21 (2x)	NPT ¾" (1 x)

\* Adapter for PG or NPT thread must be ordered separately

### 3 Electrical connection

#### 3.1 Power Electronic Unit EBN853 (Contrac) / EBN861 (Contrac)

##### 3.1.1 Analog / digital



**Note**

The electrical connection is provided by a plug on the actuator and the terminals on the electronic unit.

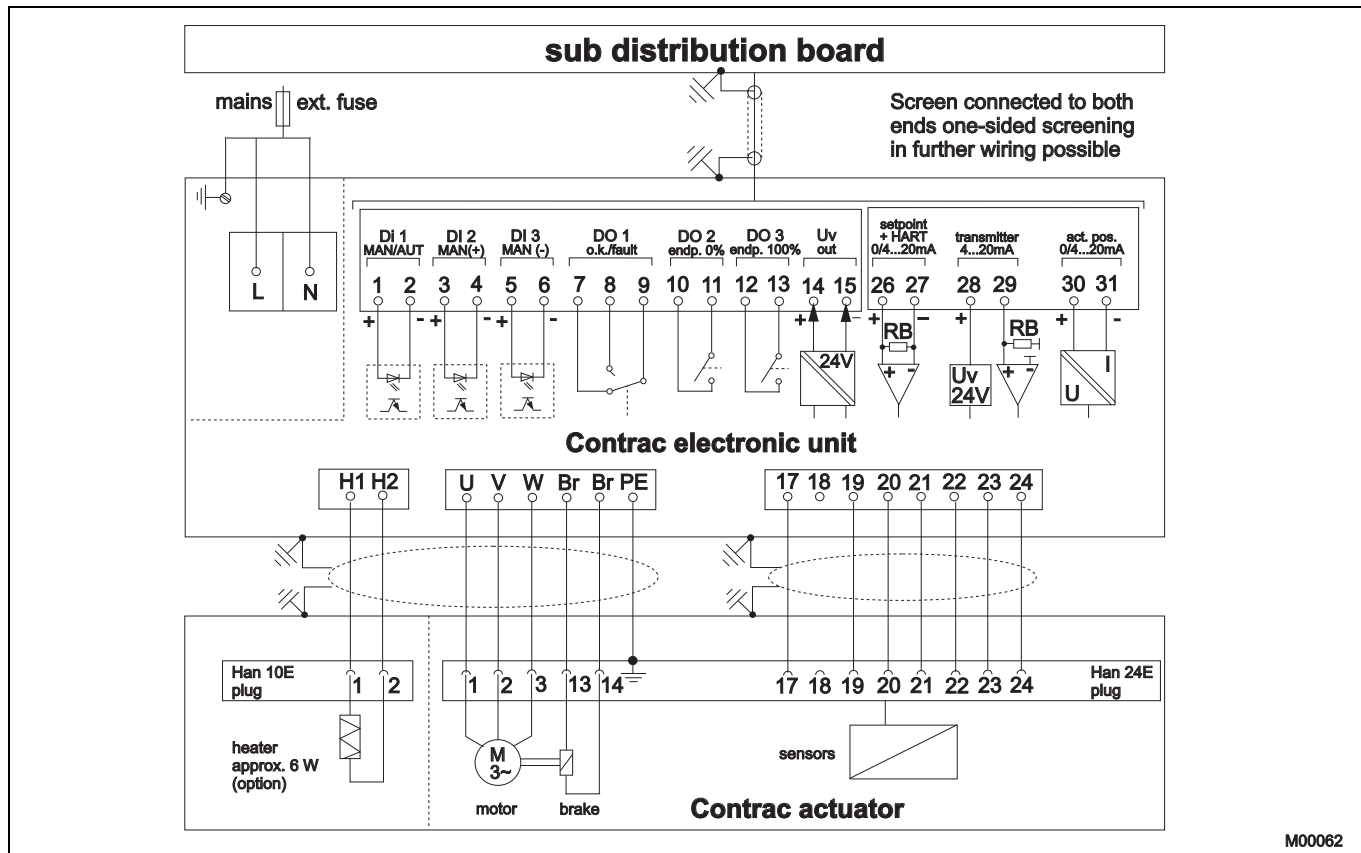

M00062

Fig. 1

**3.1.2 PROFIBUS DP**

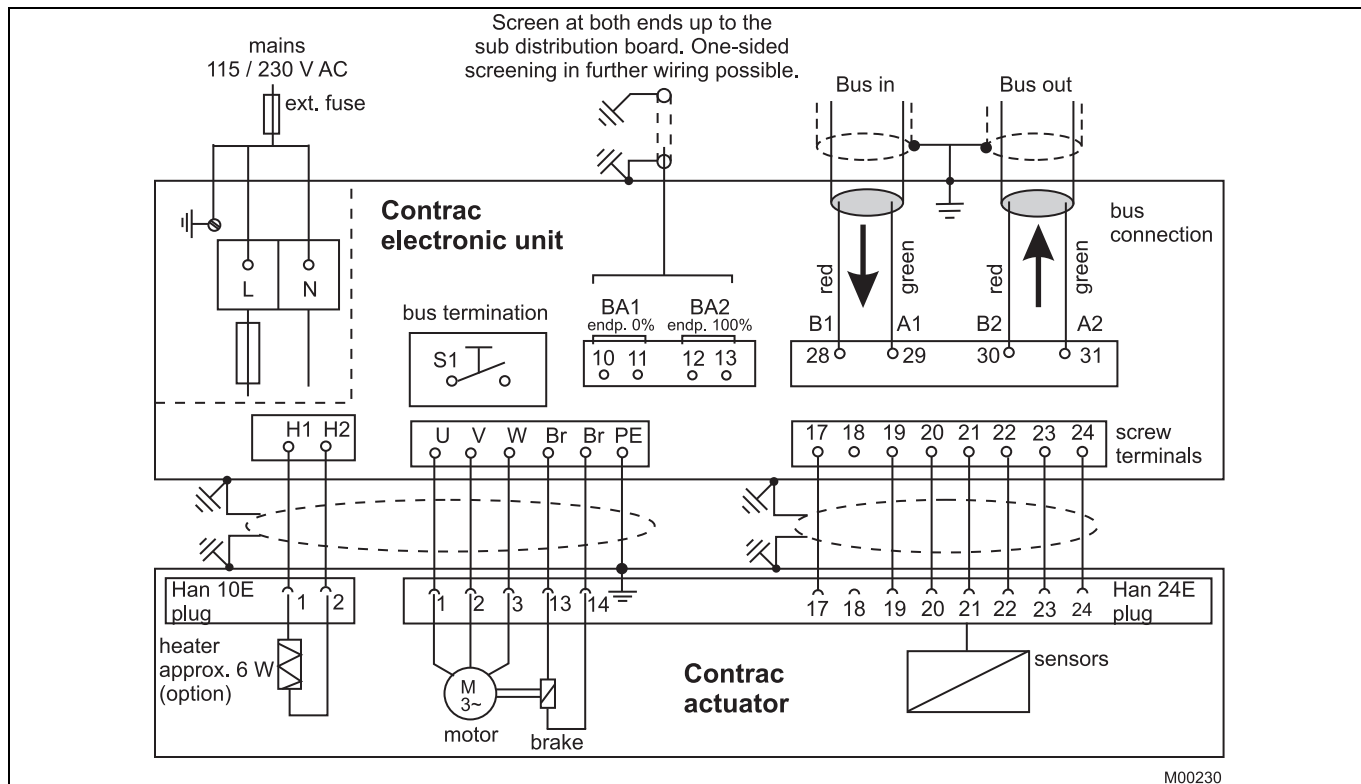

Fig. 2

**3.2 Power Electronic Unit EBS852 (Contrac) / EBS862 (Contrac)**

**3.2.1 Analog / digital**



**Note**

The electrical connection is provided by a plug on the actuator and the terminals on the electronic unit.

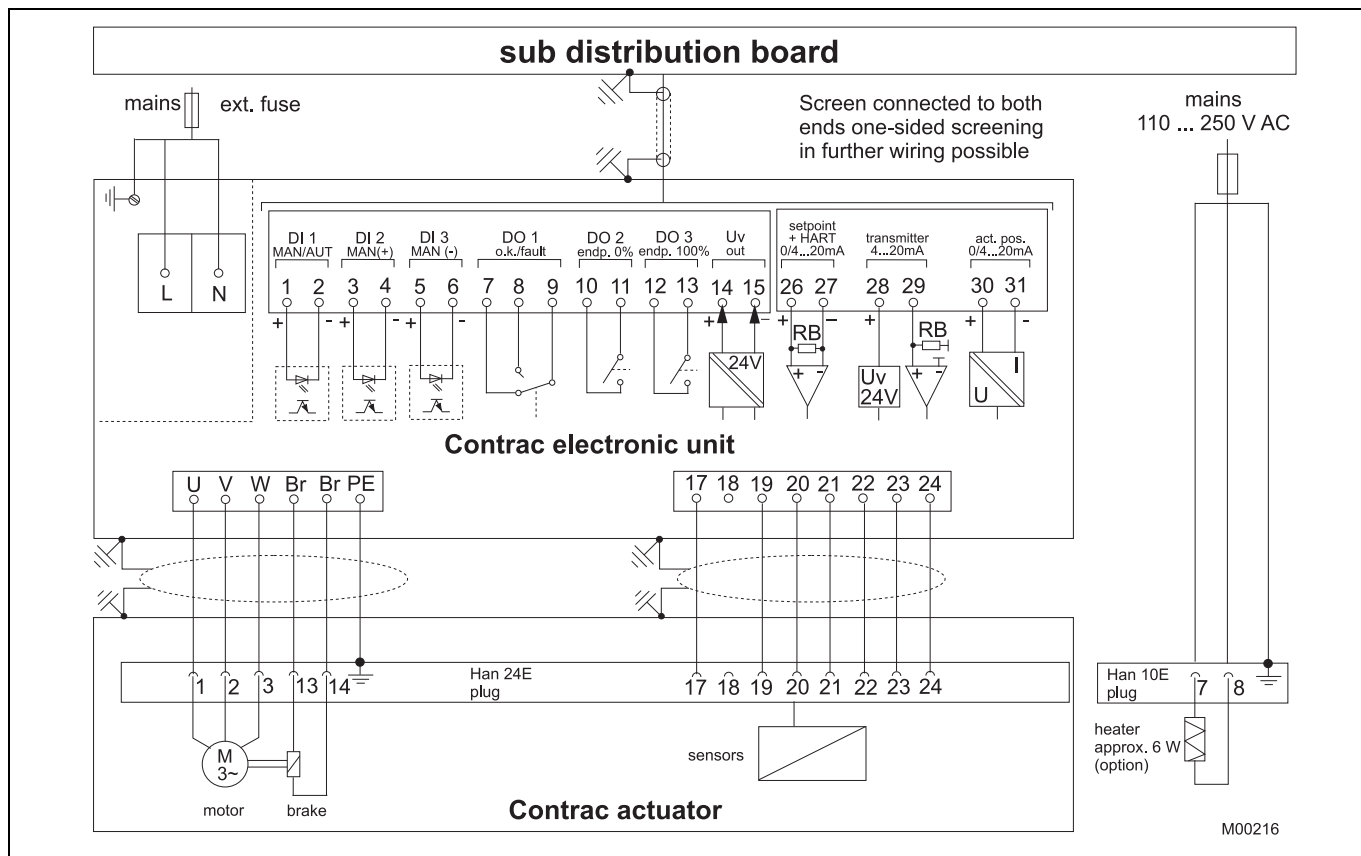
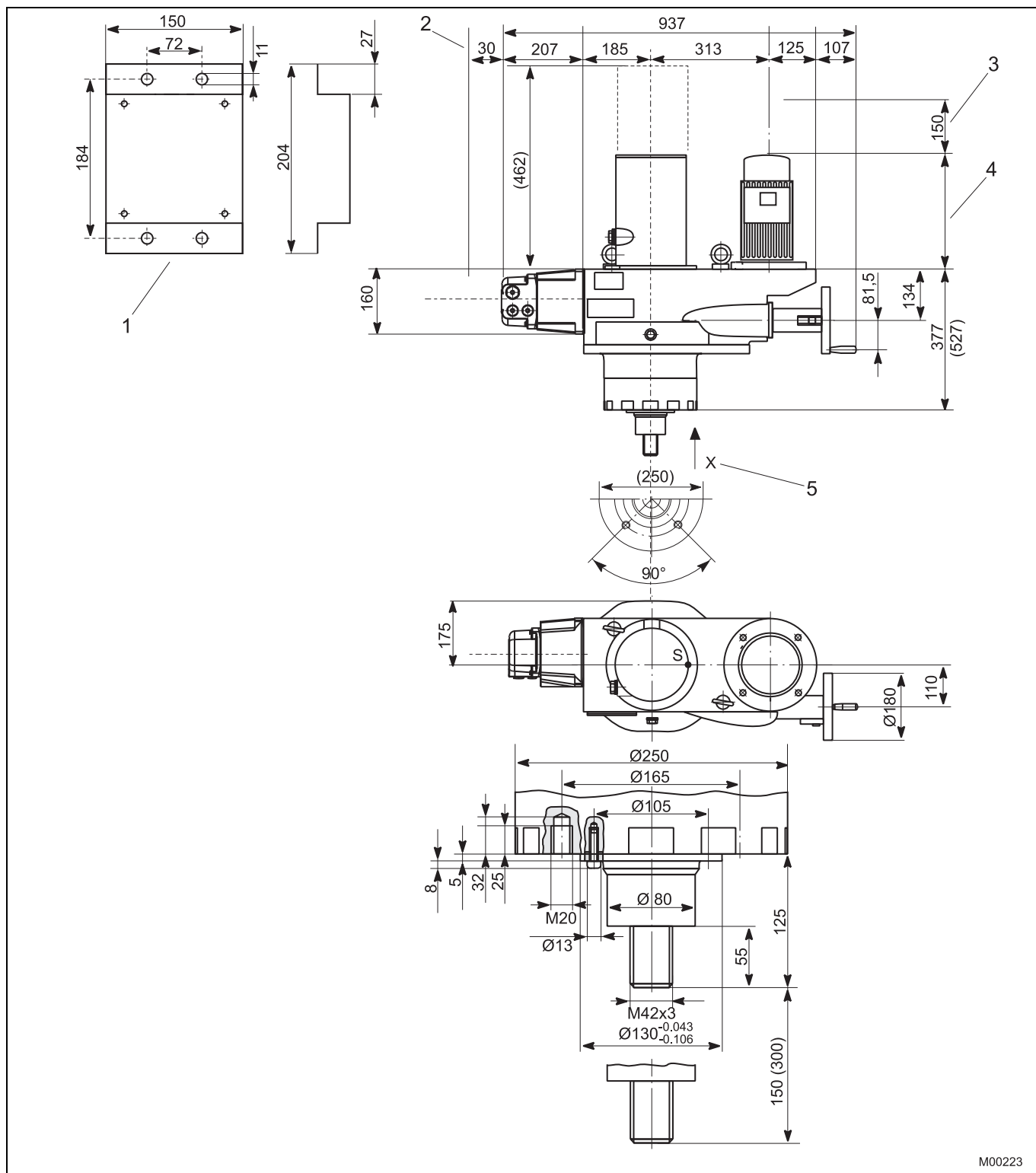

Fig. 3

## 4 Dimensions

### 4.1 Linear actuator



M00223

Fig. 4 Dimensions in mm (values in parentheses for actuators with max. 300 mm stroke)

- |                              |                                                       |
|------------------------------|-------------------------------------------------------|
| 1 Plug holder (not to scale) | 2 Space for plug removal                              |
| 3 Space for motor removal    | 4 Max. 380 mm (RSD100-1.5), max. 455 mm (RSD100-10.0) |
| 5 View "X"                   |                                                       |



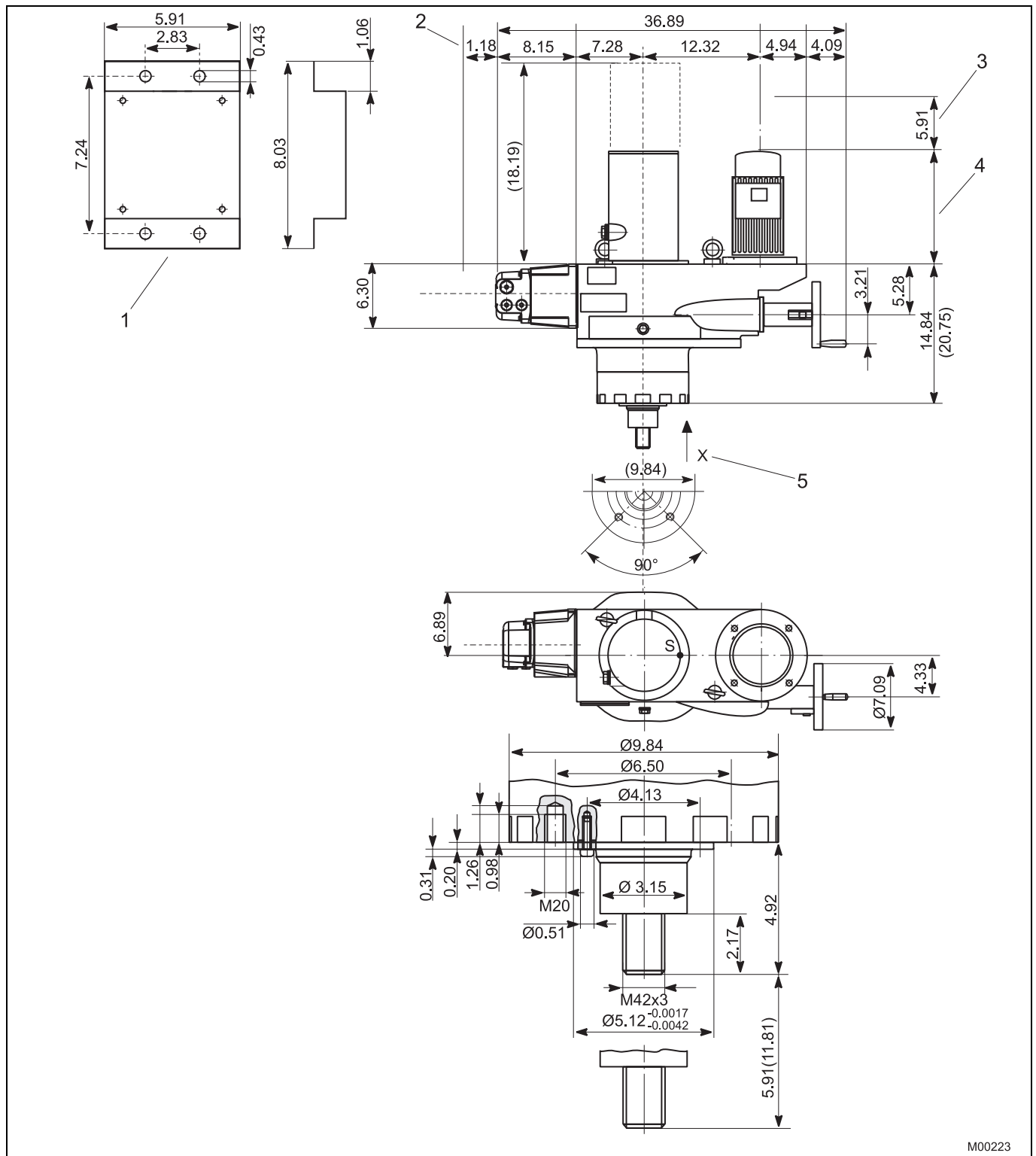

M00223

Fig. 5 Dimensions in mm (values in parentheses for actuators with max. 11.8 inch stroke)

- |                              |                                                               |
|------------------------------|---------------------------------------------------------------|
| 1 Plug holder (not to scale) | 2 Space for plug removal                                      |
| 3 Space for motor removal    | 4 Max. 14.96 inch (RSD100-1.5), max. 17.91 inch (RSD100-10.0) |
| 5 View "X"                   |                                                               |

## 5 Ordering information

<b>Linear Actuator</b>		Variant digit No.	1 - 7	8	9	10	11	Code			
<b>RSD100 -1,5, RSD100-10,0</b>		Catalog No.	<b>V68662-</b>								
Rated force 100 kN (22500 lbs) (adjustable to 50%/75%/100%)											
<b>Rated stroke</b>											
150 mm				1	4						
300 mm				1	6						
<b>Rated speed</b>											
1.5 mm/s (17.0 s/in) (adjustable to 1.5 ... 0.1 mm/s) only for RSD100-1,5						1	6				
10.0 mm/s (2.5 s/in) (adjustable to 10.0 ... 0.1 mm/s) only for RSD100-10,0						1	7				
<b>Special actuator features</b>											
Select at least one feature per group											
<b>Electrical connection</b>		plug (24-pole) complete, crimped						277			
		plug (24-pole) complete, terminals						278			
		plug bottom part covered				1)		279			
<b>Ambient temperature range</b>		-10 ... 65 °C (15 ... 150 °F)						344			
		-30 ... 50 °C (-20 ... 130 °F)						341			

<b>Additional ordering information</b>											
								Code			
Electrical connection thread		Set NPT adapter (joint metric / NPT thread)						680			
		Set PG adapter (joint metric / PG thread)						681			
Anti condensation heater								360			
Identification on data label		(alphanumeric, max. 32 characters)						294			
Data label with US units								253			
Accessories		cover for male plug (24 pole)						337			
Accessories		plug holder						338			
Factory certificate 2.1 acc. to EN 10204								291			
Certificate B acc. to EN 10204								292			
Assembly with valve at ABB		(order and pos. no. of valve required)						481			
<b>Operating instruction</b>		(specify total quantity required, 1 copy without extra charge)									
German		(no specification for 1 copy)						Z1D			
English		(always state Code-No.)						Z1E			

1) female plug with cables to be ordered with electronic unit

### Attention!

Electronic unit to be ordered separately

**Note:** Delivery time for max. 2 pcs. For 3 pcs. or more delivery time on request.



# Contact us

## **ABB Ltd.**

### **Process Automation**

Salterbeck Trading Estate  
Workington, Cumbria  
CA14 5DS  
UK

Phone: +44 (0)1946 830 611

Fax: +44 (0)1946 832 661

## **ABB Inc.**

### **Process Automation**

125 E. County Line Road  
Warminster, PA 18974  
USA

Phone: +1 215 674 6000

Fax: +1 215 674 7183

## **ABB Automation Products GmbH**

### **Process Automation**

Schillerstr. 72  
32425 Minden  
Germany

Phone: +49 551 905-534

Fax: +49 551 905-555

[www.abb.com](http://www.abb.com)

## Note

We reserve the right to make technical changes or modify the contents of this document without prior notice. With regard to purchase orders, the agreed particulars shall prevail. ABB does not accept any responsibility whatsoever for potential errors or possible lack of information in this document.

We reserve all rights in this document and in the subject matter and illustrations contained therein. Any reproduction, disclosure to third parties or utilization of its contents - in whole or in parts - is forbidden without prior written consent of ABB.

Copyright© 2010 ABB

All rights reserved